

AIR OPERATED DIAPHRAGM PUMP
airPUMP AP10 (*plastic design*)

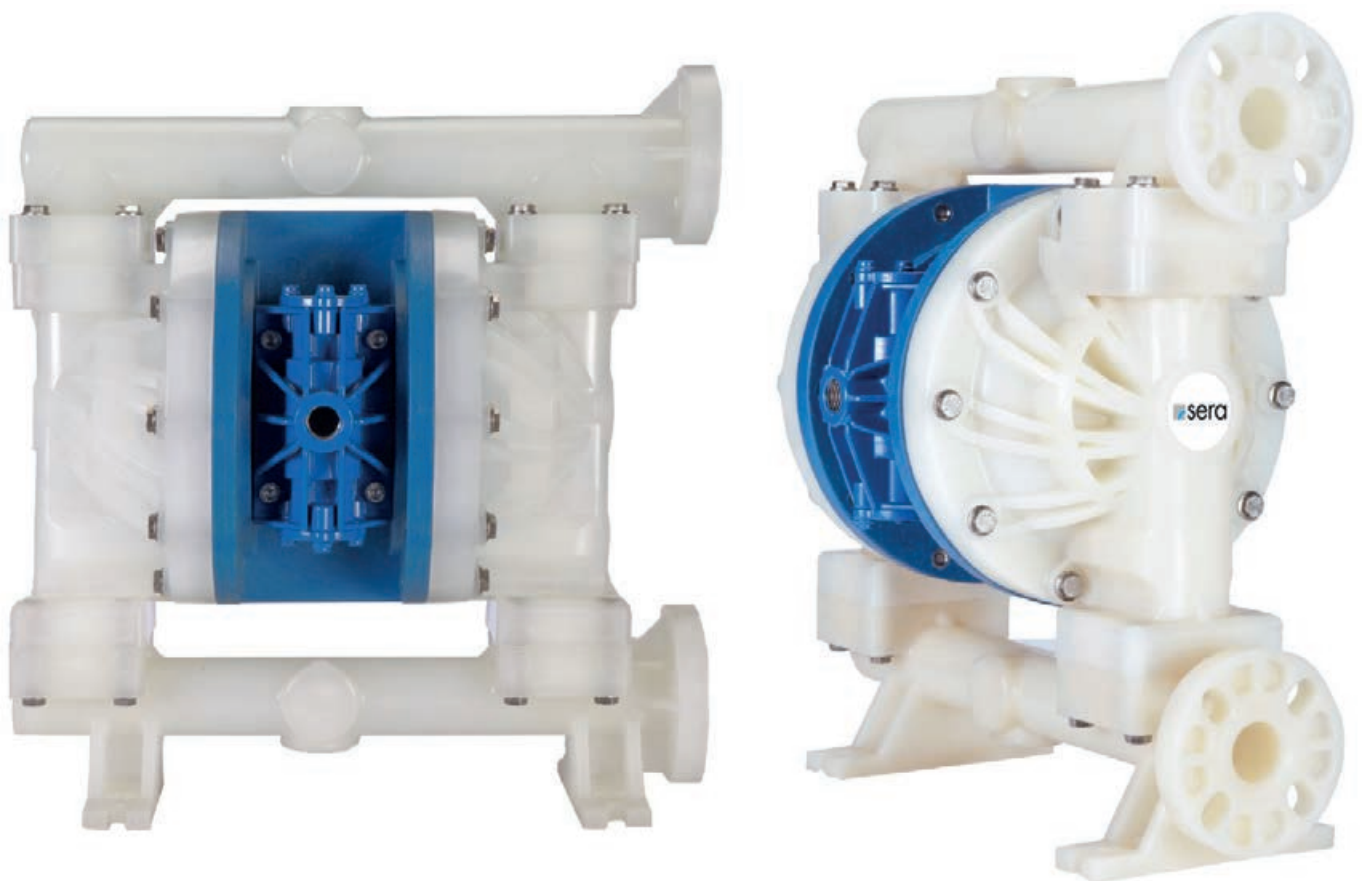

TABLE OF CONTENT

IMPORTANT INFORMATION	4
Export Information	4
Chemical Reaction Disclaimer.....	4
Unpacking & Inspection	4
SAFETY PRECAUTIONS	4
MATERIAL SPECIFICATION	7
Material Profiles.....	7
Dimensions.....	8
Characteristic curves	8
Performance data	9
INSTALLATION/OPERATION	9
Installation Drawing	9
installation / Start up.....	10
Troubleshooting Tips and Suggestions.....	11
MAINTENANCE	12
Recommended tools for servicing pump	12
Wet End Servicing (Installing Wet End Kit).....	12
Disassembly	12
Mounting	14
Air End Servicing (Installing Air End Kit).....	17
Shaft, Bushing and O-ring Replacement	17
Air Valve O-Ring Replacement	18
Valve and Muffler Gasket Replacement	19
Replacement Air Valve Kit Installation	20
Exploded View and Spare Parts List.....	20
CLEARANCE CERTIFICATE	24
EC DECLARATION OF CONFORMITY	25

IMPORTANT INFORMATION

Export Information

U.S. Export Administration Regulations, pursuant to ECCN 2B350, prohibit the export or re-export to certain enumerated countries of air operated double diaphragm pumps in which all wetted materials are constructed from fluoropolymers without first applying for and obtaining a license from the U.S. Bureau of Industry and Security(BIS). This affects all sera airPUMP pumps constructed from PVDF with PTFE balls and diaphragms. Please

Chemical Reaction Disclaimer

The user must exercise primary responsibility in selecting the product's materials of construction which are compatible with the fluid(s) that come(s) in contact with the product. The user may consult a manufacturer's representative/distributor agent to seek a recommendation of the product's material of construction that offers the optimum available chemical compatibility. However neither manufacturer nor agent shall be liable for product damage or failure, injuries, or any other damage or loss arising out of a reaction, interaction or any chemical effect that occurs between the materials of the product's construction and fluids that come into contact with the product's components.

Unpacking & Inspection

Unpack the pump and examine for any signs of shipping damage. If damage is detected, save the packaging and notify the carrier immediately. To install the pump, follow the installation instructions provided.

SAFETY PRECAUTIONS



EXPLOSION HAZARD

sera airPUMP with standard materials of construction should not be used with halogenated hydrocarbons. Halogenated hydrocarbon solvents can cause explosion when used with aluminum components in a closed (pressurized) system. sera airPUMPs with standard materials of construction contain aluminum components and will be affected by halogenated hydrocarbon solvents.

1-1-1 Trichloroethane and Methylene Chloride are the most common halogenated hydrocarbons. However, other halogenated hydrocarbon solvents are suspect if used either as part of paint or adhesive formulation, or for clean-up flushing. For applications that may involve halogenated hydrocarbons, contact **sera** to discuss the availability of alternative pump materials of construction.



WARNING

sera airPUMPs maximum temperature limits are based upon the material's mechanical stress only. Maximum temperature is application dependent. Consult a chemical resistance guide or the chemical manufacturer for chemical compatibility and temperature limits.



WARNING

Chemical Hazard. This pump is used for transferring many types of potentially dangerous chemicals. Always wear protective clothing, eye protection and follow standard safety procedures when handling corrosive or personally harmful materials. Proper procedures should be followed for draining and decontaminating the pump before disassembly and inspection of the pump. There may be small quantities of chemicals present during inspection.

**WARNING**

Hot surfaces. **sera** airPUMPs are capable of handling liquids with temperatures as high as 104°C (220°F). This may cause the outer areas of the pump to become hot as well and could cause burns.

**WARNING**

If a diaphragm rupture occurs, material being pumped may be forced out of the air exhaust. Proper care should be taken, always wear protective clothing, eye protection & follow standard safety procedures.

**WARNING**

For polypropylene or PVDF pumps do not exceed 6.9 bar (100 psig) air supply and 8.3 bar (120 psig) for aluminum and stainless steel.

**WARNING**

When pumping hazardous liquids, or operating the pump in an enclosed room, it is important to pipe the exhaust air to a safe area.

**WARNING**

Pump exhaust may be loud and contain particles. Wear appropriate ear and eye protection. In the event of a diaphragm rupture material can be forced out of the air exhaust muffler. If product is hazardous or toxic, pipe exhaust to appropriate safe area.

**CAUTION**

Before attaching air supply to pump to make sure all airline debris is clear. It is recommended to use a minimum 5 μ (micron) air filter before the air valve.

**CAUTION**

Do not over-tighten the air inlet fitting or muffler. Too much torque could damage the air valve or muffler plate.



CAUTION

Before maintenance or repair, close the compressed air line supply valve, bleed the pressure and disconnect air line from the pump. Discharge line may also be pressurized. Any pressure must be relieved prior to servicing. Remove suction / discharge lines & drain the pump.



CAUTION

If pump is used with materials that tend to solidify or settle, the pump should be flushed after each use to prevent damage.



CAUTION

Use only genuine **sera** replacement parts to assure compatibility and longest service life.



CAUTION

Check the temperature limits for all wetted components when choosing pump materials. See table below.

MATERIAL SPECIFICATION

MATERIAL PROFILES

Material	Chemical composition	Description	Operating temperature	
			min.	max.
PP	Pure Polypropylene	Thermoplastic that is resistant to alkali and strong acids.	0°C (32°F)	70°C (158°F)
PVDF	Pure Polyvinylidene Fluoride	Strong fluoropolymer with excellent chemical resistance.	-12°C (10°F)	104°C (220°F)
Stainless Steel	316 Stainless Steel	Excellent chemical resistance, high tensile and impact strength, abrasion resistant.	Limited by other materials used	
Aluminium	ADC 12, LM24, LM25	Moderate chemical resistance with good impact strength and abrasion resistance.	Limited by other materials used	
Buna	Acrylonitrile-butadiene Rubber	General purpose elastomer. Resistant to oil, water, solvent, and hydraulic fluid.	-12°C (10°F)	88°C (190°F)
EPDM	Ethylene Propylene Diene Rubber	Good resistance to mild acids, detergents, alkalis, ketones, and alcohols.	-40°C (-40°F)	121°C (250°F)
FKM	Fluorocarbon Rubber	Good chemical resistance and high temperature properties. Resistant to most acids, aliphatic, aromatic, and halogenated hydrocarbons, oils, grease, and fuels.	-40°C (-40°F)	177°C (350°F)
Neopren	Chloroprene Rubber	General purpose elastomer with good resistance to moderate chemicals, oils, grease, solvents, and some refrigerants.	-18°C (0°F)	100°C (212°F)
Santopren	Fully cured EPDM rubber particles encapsulated in a polypropylene (PP) matrix	Thermoplastic elastomer with good abrasion resistance with chemical resistance to a wide range of solvents and chemicals. Injection molded with no fabric layer.	-40°C (-40°F)	107°C (225°F)
Hytrel	Thermoplastic polyester elastomer	Combines resistance and flexibility of elastomers with the strength of plastics. Resistant to acids, bases, amines, and glycols. Injection molded with no fabric layer.	-29°C (-20°F)	104°C (220°F)
PU	Polyester Urethane	Thermoplastic that exhibits excellent abrasion resistance. Injection molded with no fabric layer.	0°C (32°F)	66°C (150°F)
PTFE	Polytetrafluoroethylene	Chemically inert. Resistant to a wide range of chemicals.	4°C (40°F)	107°C (225°F)
FEP	Fluorinated Ethylene Propylene	Similar to PTFE in composition and chemical resistance. Used to encapsulate FKM o-rings for superior chemical resistance.	-40°C (-40°F)	107°C (225°F)

DIMENSIONS

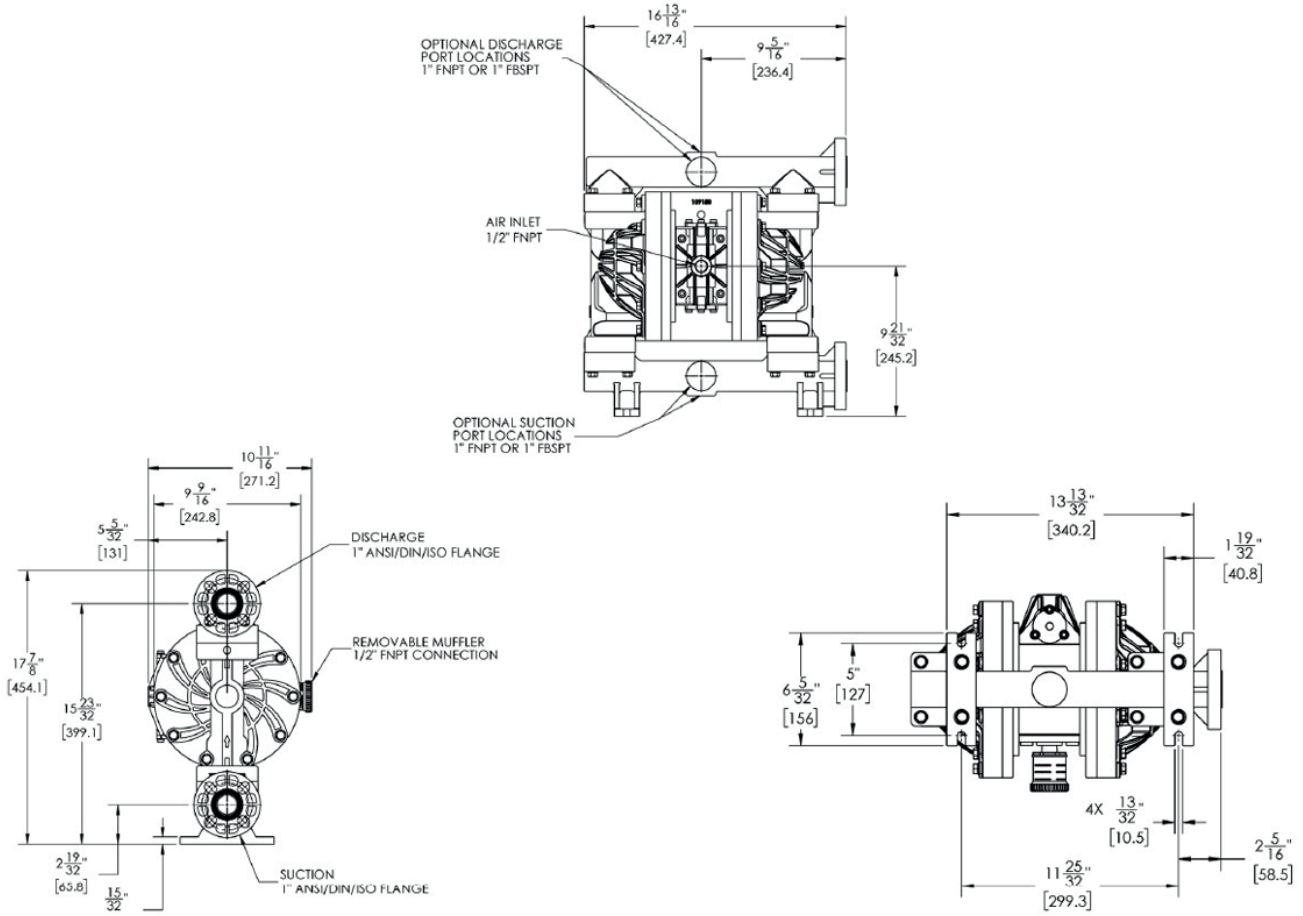

CHARACTERISTIC CURVES

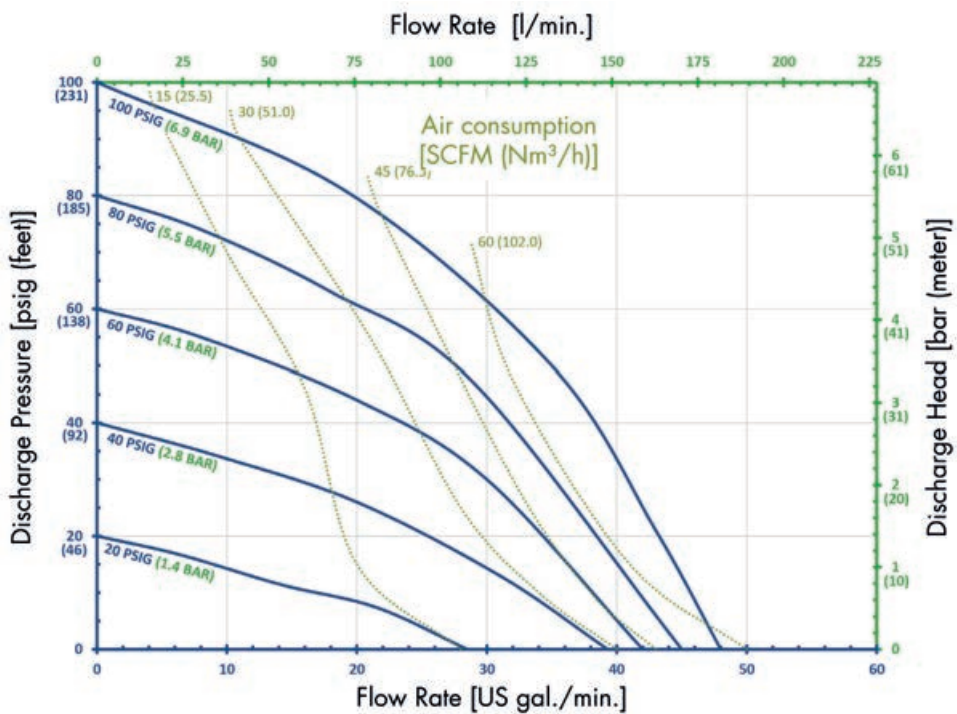

PERFORMANCE DATA

Air operated diaphragm pump AP10 (Plastic)			
Max Flow Rate:	185 Liter/min. (49 gal/m)	Suction/Discharge Size:	1" ANSI/DIN/ISO-Flansch
Displacement Per Stroke:	0,32 Liter (0.084 gal)	Air Inlet/Exhaust Size:	½" FNPT / ½" FNPT
Max Outlet Pressure:	6,9 bar (100 psig)	Air Consumption @ 6,9 bar:	88 Nm ³ /h (52 sfc _m)
Max Particle Size:	6,4 mm (0.25")	Max Material Inlet Pressure:	0,7 bar (10 psig)
Noise Level:	73,6 dB(A)	Max Air Inlet Pressure:	6,9 bar (100 psig)
Max Suction Lift (Water)	dry:	3,4 mWS (11 ft.)	Weight:
	wet:	8,5 mWS (28 ft.)	
			PVDF: 15,5 kg (34.1 lbs)

INSTALLATION/OPERATION

INSTALLATION DRAWING

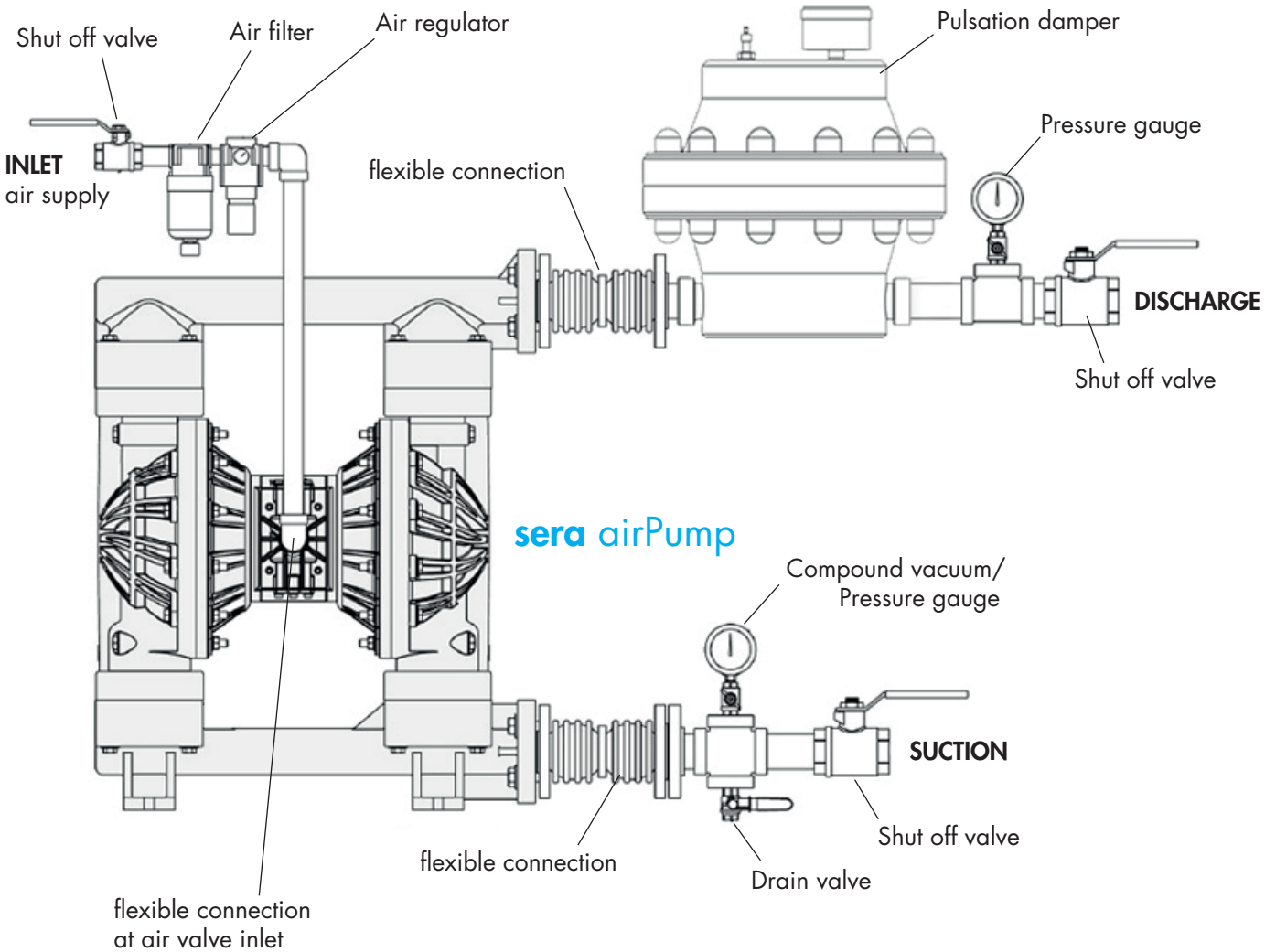

INSTALLATION / START UP

Installation and Start up

Install the pump in a vertical position or it may not prime properly. Pump should be located as close to the product being pumped as possible. Suction line length should be as short as possible and limit the number of fittings. Suction line diameter should not be reduced smaller than the suction diameter of the pump. When using rigid pipe run short sections of flexible hose or flexible connections between the pump & piping. Secure the pump to a suitable surface.

Air Supply

Connect the pump air inlet to an air supply with sufficient capacity to achieve desired performance. A pressure regulating valve should be installed to insure air supply pressure does not exceed recommended limits.

Air Valve Lubrication

No lubrication is required for the air distribution system.

Fasteners

Re-torque all fasteners before operation. Creep of housing and gasket materials may cause fasteners to loosen. Re-torque all fasteners to the torque specifications listed on the exploded view drawing in this manual.

Air Inlet & Priming

Pump will start to operate as soon as the shut-off valve is opened. It is recommended to open the shut-off valve slowly at first. Once the pump primes; the shut-off valve can be opened additionally to increase the pump's flow. If the pump is operating but not pumping any liquid see the troubleshooting section for tips & suggestions.

Accessories

Surge suppressors, spill stops & filter regulators are available and should be used with **sera airPUMP**.

TROUBLESHOOTING TIPS AND SUGGESTIONS

PUMP WILL NOT START OR CYCLE:

- Blocked liquid pipe or hose - Clean out or replace
- Clogged liquid chamber - Remove debris
- Diaphragm shaft bushing / o-ring leak - Replace o-rings
- Air valve carrier not shifting - Inspect, clean, re-oil with 10 wt. air tool oil. (aluminum air valve)
- Air valve carrier not shifting - Inspect, replace seals (polypropylene air valve)

ERRATIC CYCLING:

- Diaphragm failure - Replace diaphragm
- Valve ball not seating properly, worn or damaged – Inspect, remove debris or replace
- Leak in suction line - Inspect, repair or replace
- Diaphragm shaft bushing / o-ring leak - Replace o-rings
- Air valve carrier not shifting - Inspect, clean, re-oil with 10 wt. air tool oil. (aluminum air valve)
- Air valve carrier not shifting - Inspect, replace seals (polypropylene air valve)
- Over lubrication in air valve - Inspect, degrease, reuse. Adjust lubrication
- Excess moisture in air valve – Inspect, dry, reuse. Consider installing an air dryer
- For aluminum air valves, worn carrier or valve bore – measure carrier and valve bore, diametrical clearance should be between 0,05 - 0,088mm. Replace worn components as needed
- For plastic air valves, worn carrier seals – replace carrier seals if there is no longer interference between seals and valve bore

PUMP CYCLES BUT WILL NOT PUMP:

- Too much suction lift - Reduce suction lift or fill liquid chambers with liquid
- Leak in suction line - Inspect, repair or replace
- Valve ball not seating properly, worn or damaged - Inspect, remove debris or replace
- Clogged suction pipe or hose - Inspect & clear
- Clogged strainer if used - Inspect & clear
- Diaphragm failure - Replace diaphragm

PUMPED LIQUID RELEASED FROM AIR EXHAUST:

- Diaphragm failure - Replace diaphragm
- Outer plate unthreading - Tighten & re-torque

MAINTENANCE

Recommended tools for servicing pump

- 13 mm (or 1/2") box wrench
- 30mm socket wrenches (2x)
- Snap ring pliers
- hex wrenches (5mm and 6mm)
- O-Ring pick
- Torque wrench

Wet End Servicing (Installing Wet End Kit)

- Relieve airline pressure and fluid line pressures before conducting maintenance.
- The pump can be drained by turning it upside down and allowing fluid to drain into an appropriate container. Use proper safety equipment when conducting maintenance as internal components may still contain the pumped media.
- Lubricate all stainless steel to stainless steel fasteners to prevent galling. Torque values listed in the back of this manual are for lubricated fasteners.

DISASSEMBLY

1)

Remove the (8) discharge manifold bolts (item 11) from the discharge manifold (item 32) using a 13mm (or 1/2") wrench.

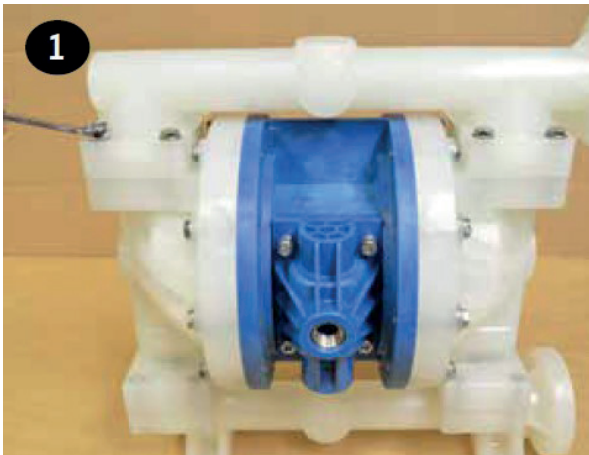

2)

The discharge seat o-rings, valve seats, and valve balls (items 13, 14, 15 & 16) can now be accessed and replaced if needed.

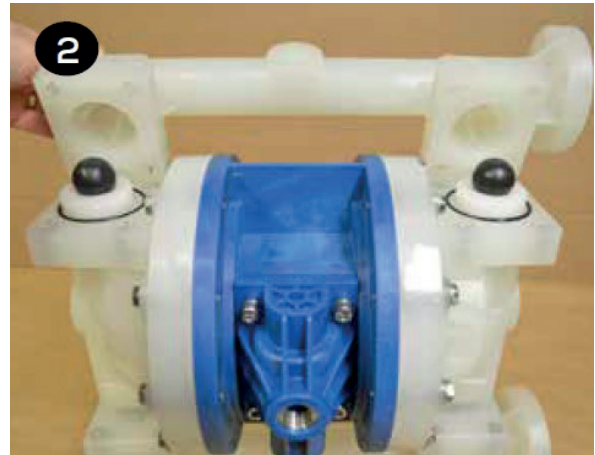

3)

Repeat the above steps for the suction manifold (item 12). The seat o-rings, valve seats and valve balls (items 13, 14, 15 & 16) are located in the liquid chambers (item 18).

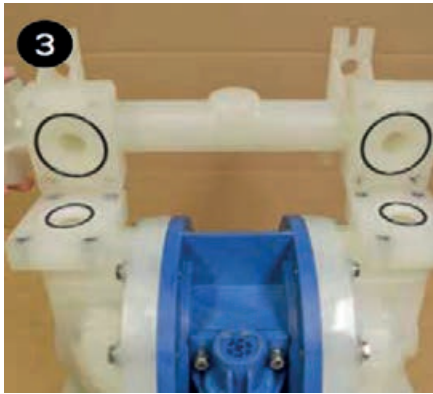

4)

Remove both liquid chambers by removing the (10) bolts (items 17) on each liquid chamber using a 13mm (or 1/2") wrench. Inspect and replace diaphragms if needed.

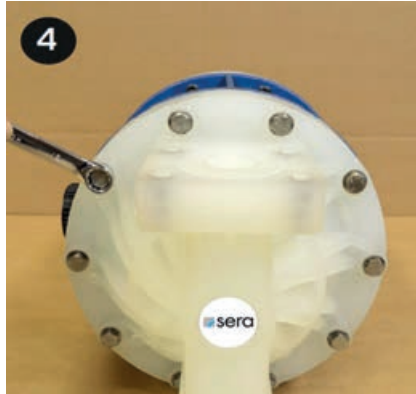

5)

To remove the diaphragms (items 20/21), begin by loosening the (2) outer plates (item 19) using (2) 30mm wrenches. Use 6-sided sockets or wrenches to prevent damage to the hex portion of the outer plate.



6)

Remove the outer plate, diaphragm(s), and inner plate (items 19, 20/21 & 22) from the side that is loosened. Pull or push the shaft (item 27) and remaining plates and diaphragms out of the center section. If pulling, it may be easier to grip the diaphragm if it is inverted.



7)

To remove the remaining diaphragm(s) (items 20/21) and plates (items 19 & 22) from the shaft (item 27), place the shaft in a vise fitted with soft jaws. Using a 6-sided 30mm wrench, remove the remaining diaphragm(s) and plates. Soft jaws are required to prevent damaging the shaft. A damaged shaft will result in accelerated o-ring wear. Jaws can be fitted with wood, plastic, rubber, or other soft material to prevent shaft damage.

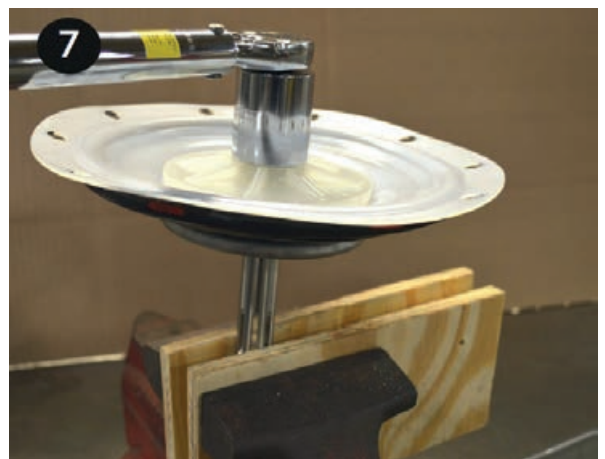

After performing required maintenance, the pump can be reassembled. The pump can also be reassembled using the disassembly instructions in the reverse order as listed above. For detailed assembly instructions, follow the steps in the Mounting section.

MOUNTING

1)
Slide the center hole of one diaphragm (item 21) over the molded in bolt of an outer plate (item 19). The air side of the diaphragm is labeled and should face away from the plastic portion of the outer plate. If the pump is fitted with PTFE diaphragms (item 20), first place a PTFE diaphragm over the molded in bolt of the outer plate (item 19). Then place the backup diaphragm (item 21) on the outer plate. The shape of the PTFE diaphragm and back up diaphragm should roughly conform to one another. See the exploded view drawing for proper orientation.



2)
Place the inner plate (item 22) over the molded in bolt. Ensure the round recess in the plate faces the diaphragm (item 21). Diaphragms are shown inverted to ease assembly.



3)
Apply a couple drops of a medium strength thread locker, such as Loctite® 246, to the molded in outer plate bolt (item 19). Thread the shaft (item 27) onto the molded in bolt until it is snug to the flat back side of the inner plate (item 22).



4)
The shaft (item 27) and shaft o-rings (item 26) should retain the lubricant that was factory applied. If they appear dry, apply a light coat of lithium thickened grease. Avoid over lubrication as it can cause decreased performance of the air distribution system.



5)
Push the shaft (item 27) through the center of the shaft bushing (item 24). It is normal for this to be a tight fit, especially if the shaft and shaft o-rings (item 26) are in good condition.



6)

The other diaphragm(s) (items 20/21) and inner/outer plates (items 19 & 22) can be installed onto the opposite end of the shaft (item 27). It may be easier to thread the molded in bolt into the shaft if the diaphragm(s) is inverted on one or both sides. This can be done by hand.



7)

Tighten and torque the outer plates (item 19). If the pump is fitted with PTFE diaphragms (item 20), it is necessary to restrict their ability to rotate when tightening the outer plates. This can be done by threading the liquid chamber bolts (item 17) through the PTFE diaphragm holes and into the center section (item 28) on each side. This will ensure that the PTFE diaphragm does not obstruct the bolts ability to thread into the center section when the liquid chambers are installed. Remove these bolts once the outer plates are torqued.

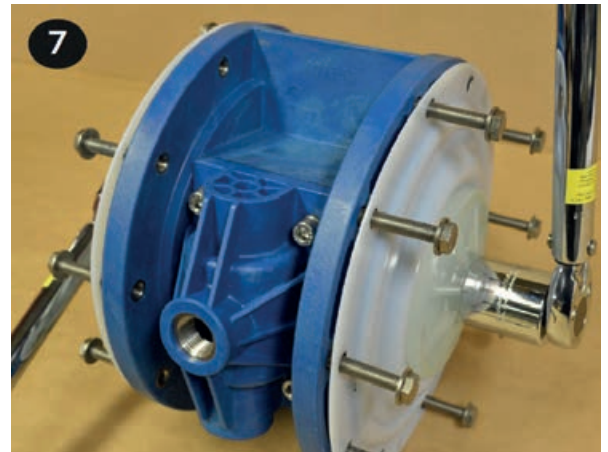

Note: When installing polytetrafluoroethylene (PTFE) diaphragms, it is important to tighten outer plates simultaneously (turning in opposite directions) to ensure tight fit.

8)

Install the liquid chambers (item 18) by placing one side over the diaphragm. Start all bolts (item 17) before tightening and torqueing. Torque all fasteners in a star pattern. Repeat to install the second liquid chamber. Ensure both chambers are orientated the same and that the inlet and outlet ports are vertical when facing the front of the pump as shown.

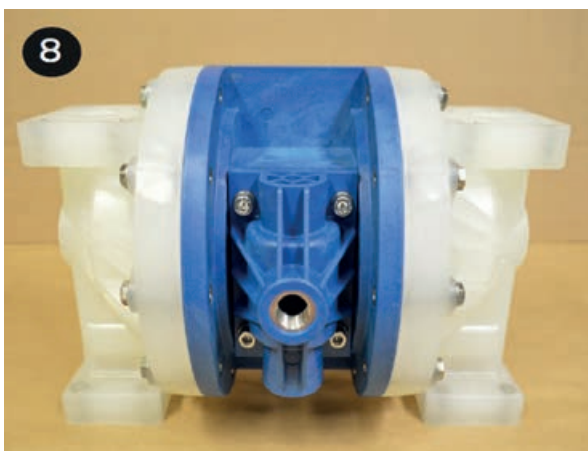

9)

Flip the pump upside down and drop the suction valve balls (item 16) into the liquid chamber (item 18) ball cages.



10)

Place the valve seats (item 15) into the seat bores of the liquid chambers (item 18). The ring gland in the valve seat (item 15) should be facing away from the valve ball. Install the valve seat o-rings (item 13) into the valve seats.

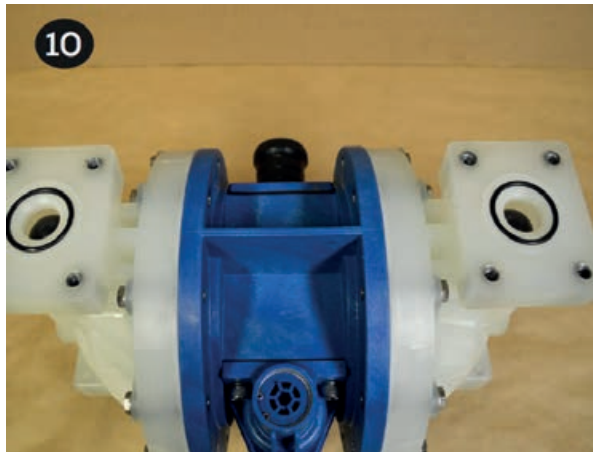

11)

Place the manifold o-rings (item 14) into the o-ring gland on the suction manifold (item 12). Place the suction manifold atop the pump and install, tighten, and torque the (8) manifold bolts (item 11).



12)

Stand the pump upright on the suction manifold feet (item 12). Place the small valve seat o-rings (item 13) on the flat faces of the liquid chambers (item 18) followed by the valve seats (item 15) on the o-rings, ensuring they are in the gland of the seat. Place the larger o-rings (item 14) into the face glands of the liquid chambers. Place the discharge manifold (item 32) atop the pump, over the components that are stacked on top of the liquid chambers. Install, tighten and torque the (8) manifold bolts.



AIR END SERVICING (INSTALLING AIR END KIT)

- Follow steps 1 – 6 in the Wet End Servicing disassembly section to access the shaft bushing (item 24) and o-rings (items 23 & 26), then follow steps below.

SHAFT, BUSHING AND O-RING REPLACEMENT

1)

Remove the shaft bushing retaining ring (item 25) and push the shaft bushing out of the center section.

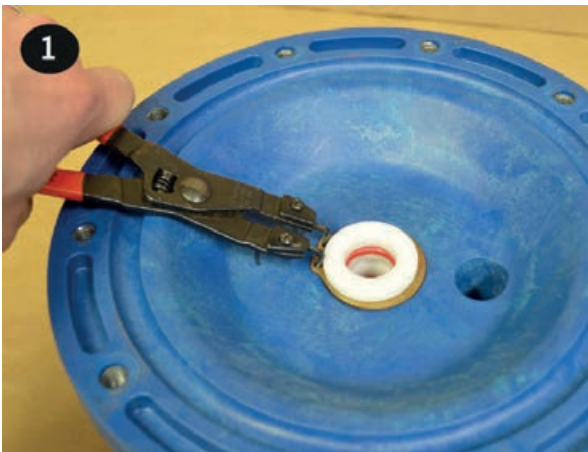

2)

Use the supplied grease packets to lightly grease the OD and ID o-rings (items 23 & 26) that come preinstalled in the new shaft bushing supplied in air end kits. Insert the shaft bushing into the center section (item 28) and reinstall the retaining ring.



3)

Inspect the shaft (item 27) for damage. It is common for shafts to become grooved during service. Grooving is normally caused by carbonized oil and/or abrasive foreign material getting trapped between the seal and the shaft. Over time, deep grooves can form in the shaft. When that occurs, it is recommended that the shaft be replaced.



- After determining if the condition of the shaft is acceptable, follow steps 5 – 12 in the Wet End Servicing – Mounting section to rebuild the rest of the pump.

AIR VALVE O-RING REPLACEMENT

1)
Plastic air valve
To replace the valve cap o-ring remove the retaining ring (item 8), then unthread the valve cap (item 6) using a 8mm hex wrench.

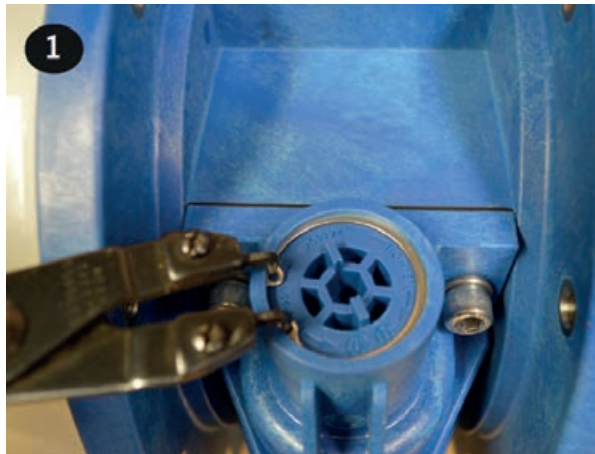

2)
Plastic air valve
Remove and replace o-ring (item 5). Install cap (item 6) and tighten until groove for the retaining ring is visible.



1)
Aluminium air valve
To replace the valve cap o-rings (item 5), remove the (3) button head cap screws (item 7) using a 5mm hex wrench.



2)
Aluminium air valve
Remove and replace o-ring (item 5). Install cap (item 6), tighten, and torque the valve cap screws (item 7). Repeat for the remaining cap.



VALVE AND MUFFLER GASKET REPLACEMENT

1)

Remove the valve body (item 3) by removing the (4) socket head cap screws & washers (items 1 & 2) that attach the valve body to the muffler plate (item 31) with a 6mm hex wrench



2)

Pull the valve body and gasket (items 3 & 30) off the front of the center section (item 28) and the muffler plate gasket, muffler plate and muffler (items 29, 31 & 33) off the back.



3)

Place the new gasket (item 30) on the air valve (item 3) and ensure the slots in the gasket align with the slots in the air valve and valve plate (item 10).

Air Valve Slide, Plate & Gasket Orientation: If the valve plate (item 10) and slide valve (item 9) are removed, ensure they are installed in the proper orientation. The flat face of the slide valve sits in the pocket of the valve carrier (item 4) so that the square cut out on the slide valve faces the smooth polished side of the valve plate.

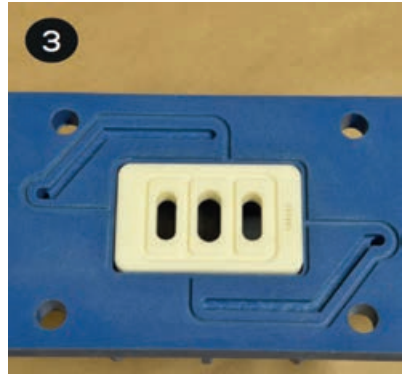
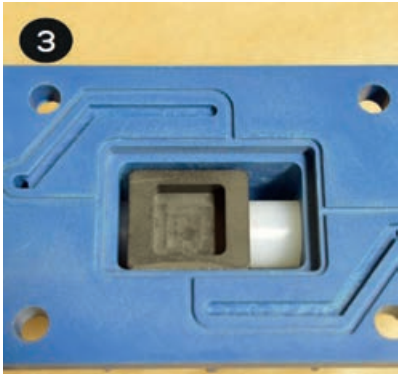
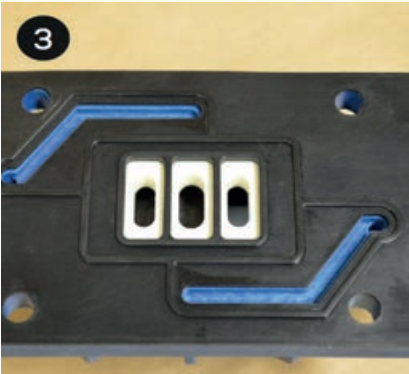

4)

Insert the (4) cap screws & washers (items 1 & 2) through the valve body and gasket (items 3 & 30) and place onto the center section (item 28). Ensure the slide valve and valve plate (items 9 & 10) are in place and the valve sits flat on the center section.

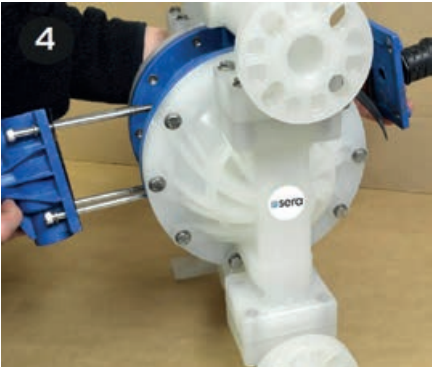

5)

Place the muffer gasket (item 29) over the (4) cap screws (item 1) on the back side of the center section (item 28) followed by the muffer plate and muffler (items 31 & 33).

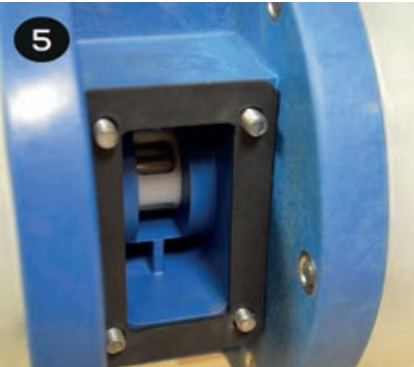

6)

Tighten and torque the (4) cap screws into the muffler plate.

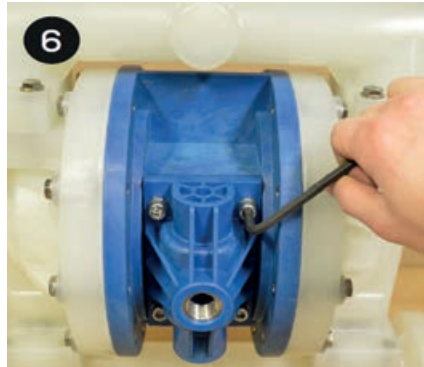

REPLACEMENT AIR VALVE KIT INSTALLATION

- 1) Remove the valve that is to be replaced by removing the (4) socket head cap screws with a 5mm hex wrench that attaches the valve body to the muffler plate.
- 2) Save the (4) cap screws, (4) lock washers, muffler plate, and muffler. All other valve components can be discarded.
- 3) Remove the packing tape that holds the air valve components in place during shipping.
- Follow steps 3 – 6 in the Valve and Muffler Gaskets section of Air End Servicing above.

EXPLODED VIEW AND SPARE PARTS LIST

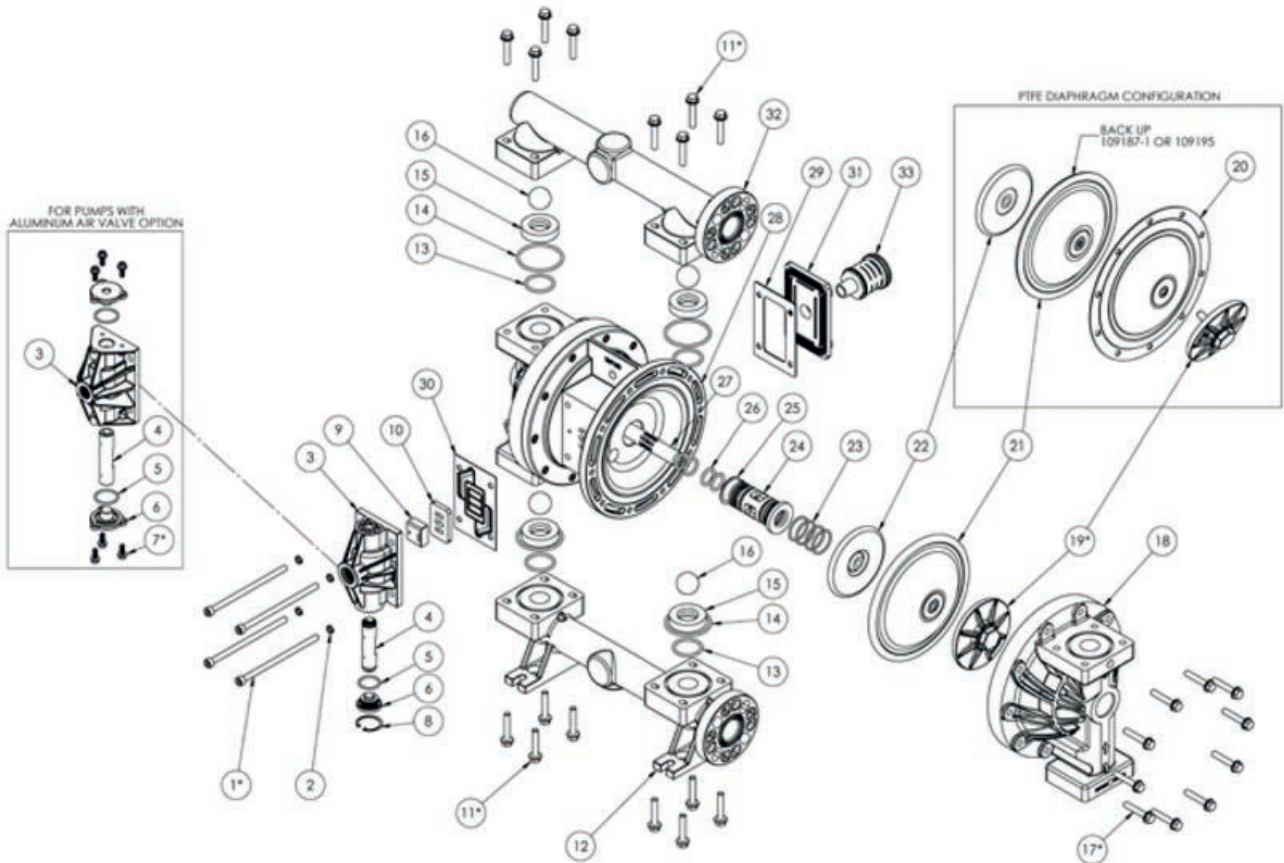

Pos.	Description	Material	Part-No.	Qty.	Set
1	CAP SCREW, SOCKET HD M8X1.25 X 150MM SS		109521	4	—
2	WASHER, LOCK M8 HIGH-COLLAR SS		109518	4	—
3	VALVE BODY		SEE AIR VALVE TABLES		V1/V2
4	VALVE CARRIER		SEE AIR VALVE TABLES		V1/V2
5	VALVE CAP O-RING		SEE AIR VALVE TABLES		A1/A2/V1/V2
6	VALVE CAP		SEE AIR VALVE TABLES		V1/V2
7	CAP SCREW, SOCKET HD M6X1.0X16MM SS		SEE AIR VALVE TABLES		V2
8	RETAINING RING, HO-137 SS		SEE AIR VALVE TABLES		V1
9	SLIDE VALVE		109258	1	V1/V2
10	VALVE PLATE		109262	1	V1/V2
11	CAP SCREW, HEX HD FLNG M8X1.25 X 45MM SS		109508	16	—
12	MANIFOLD, SUCTION,	PP PVDF	SEE MANIFOLD TABLES		—

Pos.	Description	Material	Part-No.	Qty.	Set
13	O-RING, VALVE SEAT	Buna-N	109529	4	W
		FKM	109322		
		PU	109531		
		Santoprene	109532		
		FEP-covered	109530		
14	O-RING, MANIFOLD	Buna-N	109580	4	W
		FKM	109583		
		PU	109585		
		Santoprene	109587		
		FEP-covered	109586		
15	VALVE SEAT	PP	109291	4	W
		PVDF	109296		
16	VALVE BALL	Neoprene	109204	4	W
		Buna-N	109208		
		EPDM	109212		
		FKM	109216		
		Santoprene	109220		
		Santoprene, FDA	109220-1		
		PTFE, FDA	109200		
		PTFE (weighted), FDA	109378		
Stainless steel, FDA	109369				
17	CAP SCREW	M8x1,25 L=45mm	109508	20	–
18	LIQUID CHAMBER	PP	109767-7	2	–
		PVDF	109767-8		
19	OUTER PLATE	PP	109154	2	–
		PVDF	109157		
20	DIAPHRAGM	PTFE (requires Pos. 21)	109182	2	–
21	DIAPHRAGM	Neoprene	109187-1	2	W
		Buna-N, FDA	109187-2		
		EPDM	109187-3		
		FKM	109187-4		
		Santoprene	109195		
		Santoprene, FDA	109195-1		
		Hytrel	109191		
		Hytrel, FDA	109191-1		
		PU	109436		
22	INNER PLATE	Aluminium	109169	2	–
		Stainless steel	109716		
23	O-RING		109416	4	A1/A2
24	SHAFT BUSHING		109179	1	A1/A2
25	RETAINING RING, SH-150		109468	1	A1/A2
26	O-RING, SHAFT		109423	4	A1/A2
27	SHAFT		109174	1	–
28	CENTER SECTION	PP-FRP	109150	1	–
29	GASKET, MUFFLER		109427	1	A1/A2/V1/V2
30	GASKET, AIR VALVE		109266	1	A1/A2/V1/V2

airPUMP AP10 (plastic)

Pos.	Description	Material	Part-No.	Qty.	Set
31	MUFFLER PLATE	Standard	109270	1	–
32	MANIFOLD, DISCHARGE	PP	SEE MANIFOLD TABLES		–
		PVDF			–
33	MUFFLER	Standard	109561	1	–

KIT COLUMN KEY

- W PARTS SUPPLIED IN A WET SIDE KITS
- A1 PARTS SUPPLIED IN PLASTIC VALVE AIR END KIT 109673
- A2 PARTS SUPPLIED IN ALUMINUM VALVE AIR END KIT 109595
- V1 PARTS SUPPLIED IN PLASTIC REPLACEMENT VALVE KIT 109676
- V2 PARTS SUPPLIED IN ALUMINUM REPLACEMENT VALVE KIT 109589

AP10 with air valve PP-GFK				
Pos.	Description	Part-No.	Qty.	Set
3	VALVE BODY, PP-FRP	109250	1	V1
4	VALVE CARRIER WITH SEALS	109654	1	V1
5	VALVE CAP O-RING	109646	1	A1/V1
6	VALVE CAP	109274	1	V1
8	RETAINING RING	109647	1	V1

AP10 with air valve Aluminium				
Pos.	Description	Part-No.	Qty.	Set
3	VALVE BODY, ALUMINUM	s.Pos. 34	1	V2
4	VALVE CARRIER, ALUMINUM	109453	1	V2
5	VALVE CAP O-RING	109415	2	A2/V2
6	VALVE CAP, ALUMINUM	Pos. 34	2	V2
7	CAP SCREW, SOC. HD	109513	6	V2
34	CONTAINS 3, 4, 5, 6, & 7	109599	1	V2

Connection / Porting location (N1-4, B1-4):

- | | |
|--|--|
| N1 Connection: FNPT Pos: side (Standard) | F1 Connection: Flange Pos: End (Standard) |
| N2 Connection: FNPT Pos: center, horizontal | B2 Connection: FBSP Pos: center, horizontal |
| N3 Connection: FNPT Pos: center, vertical | B3 Connection: FBSP Pos: center, vertical |
| N4 Connection: FNPT Pos: center, vertical (end discharge) | B4 Connection: FBSP Pos: center, vertical (end discharge) |

SUCTION MANIFOLD (POS. 12)														
	F1		N2		N3		N4		B2		B3		B4	
	Part No.	Qty.	Part No.	Qty.	Part No.	Qty.	Part No.	Qty.	Part No.	Qty.	Part No.	Qty.	Part No.	Qty.
AP10 PP	109118	1	109610	1	109610-1	1	109610-1	1	109610-2	1	109610-3	1	109610-3	1
AP10 PVDF	109121	1	109610-4	1	109610-5	1	109610-5	1	109610-6	1	109610-7	1	109610-7	1

DISCHARGE MANIFOLD (POS. 32)														
	F1		N2		N3		N4		B2		B3		B4	
	Part No.	Qty.	Part No.	Qty.	Part No.	Qty.	Part No.	Qty.	Part No.	Qty.	Part No.	Qty.	Part No.	Qty.
AP10 PP	109133	1	109609	1	109609-1	1	109133	1	109609-2	1	109609-3	1	109133	1
AP10 PVDF	109136	1	109609-4	1	109609-5	1	109136	1	109609-6	1	109609-7	1	109136	1

Maximum Torque Settings (Plastic designs)

Asterisk (*) from the exploded view diagram indicates fasteners to be torqued. Stainless steel to stainless steel fasteners should be lubricated to prevent galling. A Plus sign (+) on the above torque values indicates a lubricated fastener.

Design: PP or PVDF	
Pos.	Torque
1	8,5 Nm (75 in-lbs) +
7	8 Nm (72 in-lbs) +
11	16 Nm (144 in-lbs) +
17	16 Nm (144 in-lbs) +
19	38 Nm (336 in-lbs) +

CLEARANCE CERTIFICATE

i NOTE
 Inspection / repair of machines and machine parts is only carried out after the clearance certificate was filled in correctly and completely by authorized and qualified personnel.

i NOTE
 Acceptance will be refused if parts are returned to the manufacturer without a proper clearance certificate.

All industrial companies are obligated by the legal provisions for occupational health, e.g. the workplaces ordinances, the Ordinance on Hazardous Substances, the regulations for prevention of accidents and the environmental protection regulations such as the Waste Management Act and the German Household Water Act to protect their employees or man and the environment from detrimental effects when handling hazardous substances.

Should special safety precautions be necessary despite careful draining and cleaning of the product the necessary information are to be provided.

Machines which are operated with radioactive media shall only be inspected and/or repaired in the safety area of the owner by a **sera** specialized fitter.

The clearance certificate is part of the inspection-/repair order.
sera reserves the right to refuse acceptance of the order for other reasons.

DOWNLOAD

Clearance certificate

Or directly scan the QR code opposite:



Clearance Certificate

RECIPIENT

sera ProDos GmbH
 Wareneingang z. Hd. Abt. Service
 sera Straße 1
 D-34376 Immenhausen/Hessen

SENDER

Company:	<input style="width: 90%;" type="text"/>	Phone:	<input style="width: 90%;" type="text"/>
Contact partner:	<input style="width: 90%;" type="text"/>	Fax:	<input style="width: 90%;" type="text"/>
Street address:	<input style="width: 90%;" type="text"/>	E-Mail:	<input style="width: 90%;" type="text"/>
Postcode, City:	<input style="width: 90%;" type="text"/>	Your order number:	<input style="width: 90%;" type="text"/>

We confirm that we have entered the information in this clearance certificate (decontamination certificate) correctly and completely and that the returned parts have been carefully cleaned.
 The parts sent in are therefore free of residues in dangerous quantities.

<input style="width: 95%;" type="text"/>	<input style="width: 95%;" type="text"/>	<input style="width: 95%;" type="text"/>
Place, Date	Department	Signature (and company stamp)

www.sera-web.com

© 2019 sera ProDos GmbH. All rights reserved.

Original

Business name and full address of the manufacturer:

sera GmbH, sera-Straße 1, D - 34376 Immenhausen

Name and address of the person authorised to compile the technical file:

Sabine Morell, sera-Straße 1, D – 34376 Immenhausen

Description and identification of the machinery:

Air-operated diaphragm pump for dosing fluids for industrial applications.

airPUMP ¼" AP025 PP Santo
airPUMP ¼" AP025 PVDF Santo

airPUMP ¼" AP025 PP PTFE
airPUMP ¼" AP025 PVDF PTFE

airPUMP ½" AP05 PP Santo
airPUMP ½" AP05 PVDF Santo

airPUMP ½" AP05 PP PTFE
airPUMP ½" AP05 PVDF PTFE

airPUMP 1" AP10 PP Santo
airPUMP 1" AP10 PVDF Santo

airPUMP 1" AP10 PP PTFE
airPUMP 1" AP10 PVDF PTFE

airPUMP 1½" AP15 PP Santo
airPUMP 1½" AP15 PVDF Santo

airPUMP 1½" AP15 PP PTFE
airPUMP 1½" AP15 PVDF PTFE

airPUMP 2" AP20 PP Santo
airPUMP 2" AP20 PVDF Santo

airPUMP 2" AP20 PP PTFE
airPUMP 2" AP20 PVDF PTFE

The machinery fulfils all the relevant provisions of this Directive:

2006/42/EC Machinery

Where appropriate, harmonised standards used:

EN ISO 12100:2010

Place and date of the declaration: Immenhausen, 11.02.2022

Identity and signature of the person empowered to draw up the declaration on behalf of the manufacturer or his authorised representative:

34376 Immenhausen

S. Morell
Quality Management

NOTES

NOTES

FOLLOW US



sera GmbH
sera-Str. 1
34376 Immenhausen
Germany
Tel. +49 5673 999 00
Fax +49 5673 999 01
info@sera-web.com
www.sera-web.com

TM14 AP05-K-02 EN 02/2022. **sera** is a registered trademark of **sera** GmbH.
Technical details subject to change. **sera** shall not accept any liability for errors or omissions or for printing errors.