

PISTON PUMP 409.2...K



PUMP TYPE

RF/R/MF/M 409.2 - 8 K	C 409.2 - 8 K Pro+
RF/R/MF/M 409.2 - 12 K	C 409.2 - 12 K Pro+
RF/R/MF/M 409.2 - 18 K	C 409.2 - 18 K Pro+

i NOTE

Record the exact type and serial number here ► can be read off the type plate on the pump.
These data are important in the case of queries or for ordering spare and/or wear parts and must always be stated.

TYPE:

SERIAL NO:

i NOTE

Keep the operating manual for future use!

! ATTENTION

Subject to technical modifications!

Quality notes

The **sera** quality management and quality assurance system is certified in accordance with DIN EN ISO 9001:2015.
The **sera** product complies with the applicable safety requirements and accident prevention regulations.

About this instructions

Special notes in these instructions are marked with text and danger symbols.

NOTE

Notes or instructions that facilitate work and ensure a safe operation.

ATTENTION

The non-observance of these safety instructions can result in malfunctions or material damages.

WARNING

The non-observance of these safety instructions can lead to material damages and personal injuries.



Note on the additional instructions „SAFETY INSTRUCTIONS“.

These technical manual is divided into the following main parts:

TRANSPORT & STORAGE	page 6
PRODUCT DESCRIPTION	page 7
TECHNICAL DATA	page 18
ASSEMBLY / INSTALLATION	page 23
OPERATION / EXPLOSION-HAZARDOUS AREAS	page 30
START-UP	page 32
ELECTRICAL CONNECTION	page 33
MAINTENANCE	page 34
FAULT ANALYSIS / CORRECTIVE ACTION	page 39
SHUT-DOWN / DISPOSAL	page 41
CLEARANCE CERTIFICATE	page 42

Depending on the pump type (see order confirmation) the following additional instructions are included:

Control PRO+	TM04
INTERFACE MODULE PROFIBUS C409.2 Pro+	TM05
INTERFACE MODULE PROFINET C409.2 Pro+	TM07
Motor ATEX	supplier documentation
AC motor	supplier documentation
Electrical actuator	supplier documentation
Electrical actuator ATEX	supplier documentation
Pneumatic actuator	supplier documentation
Frequency converter	supplier documentation
Special construction	sera drawing

TRANSPORT & STORAGE	6
General	6
Storage.....	6
PRODUCT DESCRIPTION	7
Type key	7
Type plate	8
Notes attached to the product.....	8
Materials	8
Components ...409.2 ... K	9
Components of C409.2 ... K Pro+	10
NOISE MEASUREMENT	17
VISCOSITY, PUMPED MEDIUM	17
TEMPERATURE DATA	17
TECHNICAL DATA	18
AMBIENT CONDITIONS	18
Dimensions RF409.2... K standard	18
Dimensions C409.2... K standard	19
Dimensions ...409.2 options	20
Dimensions C409.2... K options	22
ASSEMBLY / INSTALLATION	23
OPERATION / EXPLOSION-HAZARDOUS AREAS	30
Operation in Ex-zone C409.2	30
Operation in Ex-zone R/M 409.2	30
START-UP	32
ELECTRICAL CONNECTIONS	33
MAINTENANCE	34
Drive motor	34
Oil change.....	35
Overview of the tightening torques.....	35
Changing the piston seal and protective diaphragm.....	36
Spare and wearing parts	37
FAULT ANALYSIS / CORRECTIVE ACTION	39
SHUT-DOWN / DISPOSAL	41
Shut-down	41
Disposal.....	41
CLEARANCE CERTIFICATE	42



WARNING

Observe and follow the safety instructions by all means.
See the additional instructions „SAFETY INSTRUCTIONS“.
Man, machine and environment are endangered if the safety instructions are not observed.



General

sera products are checked for perfect condition and function previous to shipment.
Check for transport damage immediately after arrival of goods. If damage is found, this is to be reported immediately to the responsible carrier and the manufacturer.

Storage

An undamaged packaging protects the unit during storage and should only be opened when the product is installed.
Proper storage increases the service life of the product and includes prevention of negative influences such as heat, moisture, dust, chemicals etc.

The following storage specifications are to be observed:

- Storage place: cool, dry, dustfree and slightly ventilated
- Storage temperature and relative air humidity see Chapter „TECHNICAL DATA“.
- The maximum storage time for the standard packaging is 12 months.

If these values are exceeded, metal products should be sealed in foil and protected from condensation water with a suitable desiccant.

Do not store solvents, fuels, lubricants, chemicals, acids, disinfectants and similar in the storage room.

Type key

Type of drive (combinations possible)

- C controllable
- M not mechanically adjustable
- R mechanically adjustable
- F Motor suitable for frequency converter operation
- i Frequency converter, mounted on the motor
- K Stroke mechanism with side drive shaft and connected to the drive via a clutch
- Z twin design
- X Stroke mechanism with two opposite pump heads, combined suction and pressure side
- Y Stroke mechanism with two opposite pump heads

Series

- 204 (solenoid driven pumps)
- 409 (motor driven pumps)
- 410 (motor driven pumps)
- 411 (motor driven pumps)

Revision index

max. Nominal capacity (litre/hour (each pump head))

Displacer (type of construction)

- e Single diaphragm
- ML Multi-layer diaphragm
- KM Piston diaphragm
- K Piston

Type of control

Pro+

1

2

3

4

5

6

C

409

.

2

-

8

K

Pro+

(example)

PRODUCT DESCRIPTION

Type plate

Each **sera** pump is factory provided with a type plate. The following information can be found on this type plate.

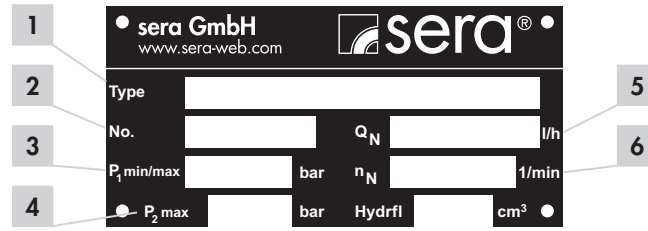

No.	Designation
1	Pump type
2	Serial number of the pump
3	Minimum/maximum permissible pressure in the pump inlet Minimum/maximum permissible pressure in the inlet cross section which the pump can be used for. Please consider that pressure depends on rotation speed, delivery rate, temperature and static pressure at the inlet.
4	Maximum permissible pressure in the pump outlet Maximum permissible pressure in the outlet cross section which the pump can be used for. Please consider that pressure depends on rotation speed, delivery rate, temperature and static pressure at the outlet.
5	Nominal delivery rate Delivery rate which the pump was ordered for, based on the nominal rotation speed n_N , the nominal delivery height p_{2max} . and the delivery medium stated in the supply contract.
6	Nominal stroke frequency

Notes attached to the product

Symbols which are directly attached to the pump, e.g. arrows for direction of rotation or symbols for fluid connections are to be observed and kept in legible condition.

Materials

The materials used are stated in the order confirmation and the product description.

Components ...409.2 ... K

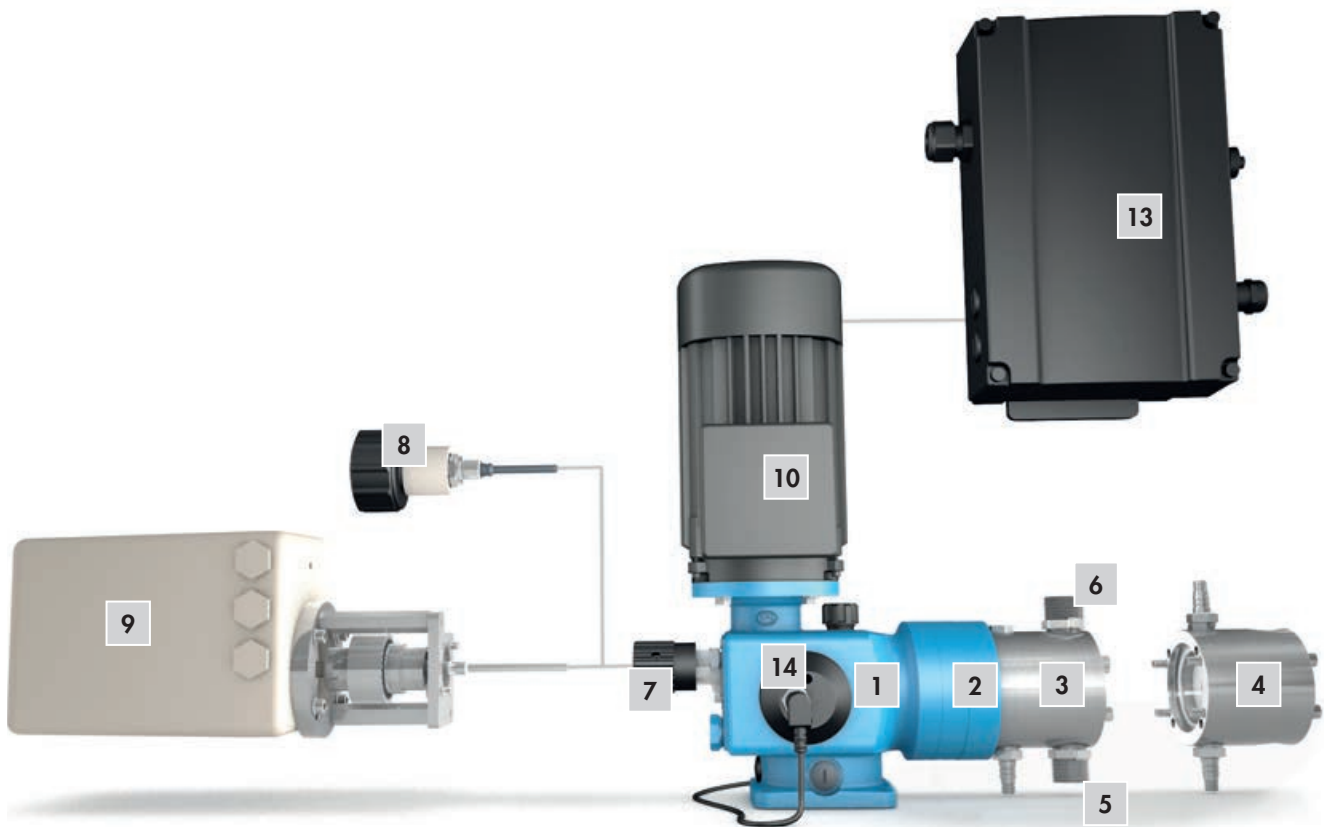

No.	Designation	Remark
1	Stroke mechanism	
2	Assembly pump	
3	Pump body	
4	Pump body with rinsing connection	option
5	Suction valve	
6	Pressure valve	
7	Manual stroke length adjustment	
8	Manual stroke length adjustment with position indicator	option
9	Stroke length adjustment with actuator	option
10	Motor	
13	Frequency converter *	option
14	Stroke frequency transmitter	option
not illustrated	Blind plug	option (M-design)
not illustrated	Motor for Ex-area *	option (R-design)
not illustrated	Actuator for Ex-area *	option
not illustrated	Pneumatic actuator *	option

*see enclosed documentation

PRODUCT DESCRIPTION

Components of C409.2 ... K Pro+



No.	Designation	Remark
1	Stroke mechanism	
2	Assembly pump	
3	Pump body	
4	Pump body with rinsing connection	option
5	Suction valve	
6	Pressure valve	
7	Manual stroke length adjustment	
8	Manual stroke length adjustment with position indicator	option
9	Stroke length adjustment with actuator	option
10	Motor	
11	Control Pro+ with removable control element	
12	INTERFACE MODULE	accessories
not illustrated	Suction lances connection	accessories

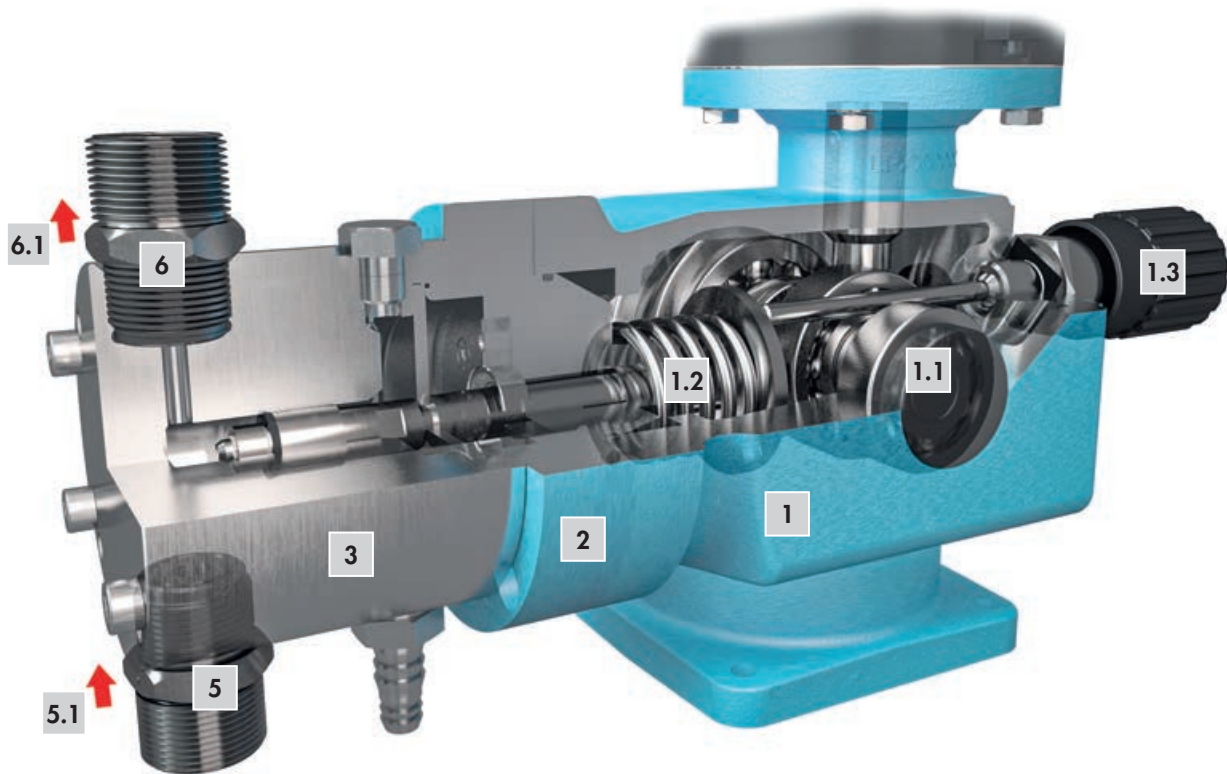

Stroke mechanism (1)

Piston diaphragm pumps of this type series use a rotary cam drive to transmit the rotation of the drive motor to the displacement body.

In case of the rotary cam drive, the eccentric (1.1) provides the pressure stroke while the suction stroke is performed by a pressure spring (return spring) (1.2).

The effective stroke length can be changed by means of an adjustable scale knob (1.3) which prevents the connecting rod from following the rotary cam up to the rear dead centre during suction stroke (see stroke length adjustment).

Pressure valve / Suction valve (5/6)

The pump valves are ball valves that only work properly in a vertical position. The condition of the valves has a deciding effect on the operating capability of the pump. Valves must be exchanged as complete units. When replacing the valves it is important to check the flow direction (5.1/6.1) .

ATTENTION

Pressure valve above, suction valve below!

PRODUCT DESCRIPTION

Assembly pump (2) / Pump body (3)

The piston (3.1) connected to the drive via the connecting rod transmits the stroke movement directly to the pumped medium (3.2). Suction- and pressure valves open and close depending on the stroke cycle of the piston.

The piston seal guaranteed lowest leakage at maximum wear resistance and low friction at high sealing quality.

The protection diaphragm (3.3) between dosing head and stroke mechanism prevents leaking media from penetrating the stroke mechanism.

Leaking media flow out at the leaking nozzle (3.4) where they can be collected or returned in the dosing tank (when the pump is mounted on top).

A transparent hose allows a visual check.

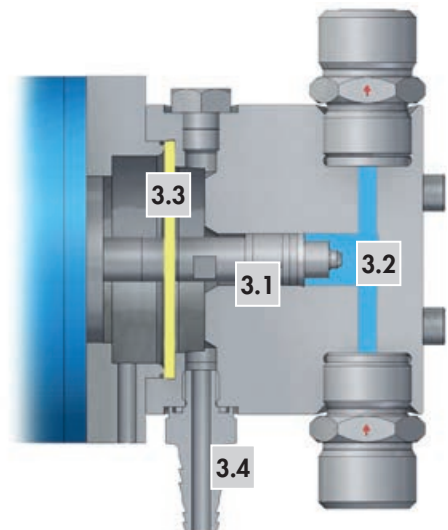

Piston pump with rinsing connection (4) (option)

In case of media which are lightly crystallizing the area after the piston is to be rinsed at regular intervals (rinsing connection 4.1).

Rinsing should be carried out in intervals (for appr. 2 minutes once an hour) while the pump is operating or again for appr. 3 minutes after the pump was switched off and restarted again.

The rinsing pressure must not exceed 0.1 bar i.e. a suitable pressure reducer is to be provided in addition to the shut-off valves and the automatic valves.

The volume flow of rinsing liquid should be between 0.5 and 1 l per rinsing process.

The rinsing liquid must be drained without pressure (free drainage downward) via the leaking nozzle (3.4).

Only non-aggressive, chemically neutral, liquid rinsing media without any solid matters are to be used.

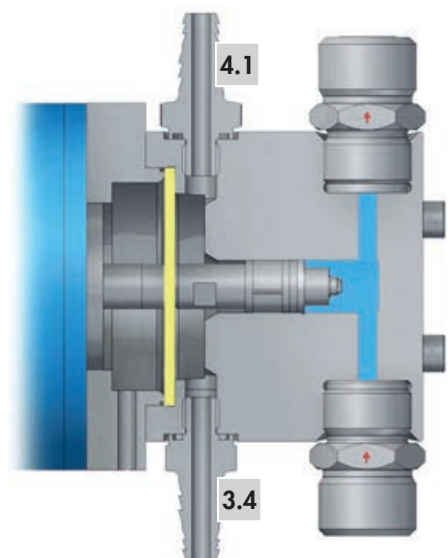

Stroke length adjustment

The delivery rate of the pump is set by changing the stroke length. The stroke length is infinitely variable between 0% and 100%..

i NOTE

A linear dosing behaviour is achieved with stroke length adjustments between 20% and 100%. Below 20% stroke length, electronic stroke length detection is no longer ensured for pumps of the C409.2 serie. In this case, the warning „Out off range calibrate“ appears, followed by the error message „No stroke recognition!“.

Manual stroke length adjustment (standard) (7)

The effective stroke length of the connecting rod is changed by turning the scale knob. The stroke length should be adjusted during operation of the pump. The set stroke length can be read off a scale, e.g. 75%. With the 20-steps adjustment on the scale knob, the stroke length can be set individually with a tolerance of 0.5%..

A protecting cap can be provided for the protection of the stroke length adjustment against unintentional adjustment.

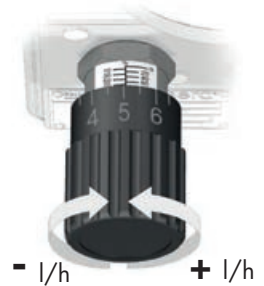

Manual stroke length adjustment by a dial scale with indication of percent (option) (8)

The stroke length is adjusted by turning the hand wheel. The stroke length should be adjusted during operation of the pump. The set stroke length can be read off the percent scale (the example shows a set stroke length of 65%). In delivery state, the stroke length adjustment is factory set to 50%.

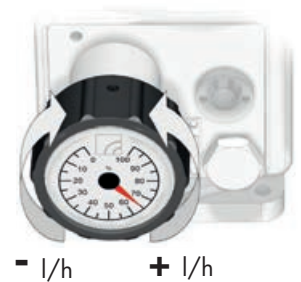

! ATTENTION

The dial scale with indication of percent may become misadjusted during transport. If the indicator does not match the 50% setting, then the percent scale must be re-adjusted during operation (!) of the pump!

Adjusting the percent scale:

- Switch on the pump.
- Loosen setscrew (8.1).
- Remove percent scale (8.2) from the hand wheel (8.3).
- Manually turn the percent scale to 0% setting.
- Use the hand wheel to set the stroke length to 0%.
- Turn hand wheel clockwise until there is no further stroke movement (connecting rod does no longer hit the adjusting spindle (8.4)).
- Insert percent scale again.
- Use the setscrew to secure the percent scale to the hand wheel.
- Adjust desired stroke length.

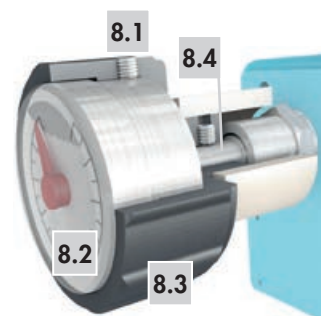

Automatic stroke length adjustment by means of an electrical actuator (9)

The electrical actuator is directly mounted to the stroke mechanism of the pump. A clutch transmits the rotary motion of the actuator drive shaft to the adjusting spindle. The axial displacement is compensated in the clutch.

In case of dosing pumps with electrical actuator, a manual adjustment of the stroke length on the pump is no longer possible. (Exception: actuator with hand wheel)

The actuator is equipped with two integrated limit switches as well as a position potentiometer for position feedback as standard. Both limit switches are factory set so that the drive will switch off at a stroke length of 0% and 100%, even if a control voltage is applied.

This guarantees that adjustments can only be made within the permissible range. The position potentiometer is driven by a safety clutch which prevents damage caused by incorrectly adjusted limit switches.

Activation is performed by appropriate control units (see **sera** - accessories).

The set stroke length can be read off on the pump (percent scale).

Information on the electrical connection is given inside the cover of the actuator.



ATTENTION

The adjustment is only possible when the pump is running!

Automatic stroke length adjustment by means of an electrical actuator with integrated positioner

same as Chapter „Automatic stroke length adjustment by means of an electrical actuator“, additionally:

This positioner which is integrated in the actuator enables an actuator setting from 0...100% that is proportional to the connected input signal.

As an option, the actuator can also be provided with a collective interference signal. Information on the electrical connection is given inside the cover of the actuator.

Drive motor C409.2

A **sera** motor pump of series C409.2 is driven by a three-phase-motor controlled by the electronics.

A protective motor switch is not necessary due to the fact that a thermic overload protection is integrated in the pump for the protection of the motor.

Drive motor ...409.2

sera motor pumps R(F)/M(F)409.2 are driven either by a three-phase motor.
Standard: three-phase motor (with PTC thermistor; suitable for operation with frequency converter).

Motor connection

In case of a three-phase motor		Δ Delta connection	Y Star connection
The motor connection depends on the voltage indication on the type plate and the applied supply voltage.			
<i>Example:</i>			
Indication on the type plate:	Δ 230V/ Y400V 50Hz		
Three-phase power system on sit:	Y400V 50 Hz		
Correct motor connection:	Star connection (Y)		
In case of an AC motor			
The AC motor has a main and an auxiliary winding. The running capacitor is switched in series to the auxiliary phase.			

Direction of rotation

The direction of rotation of the drive motor is arbitrary.

Terminal box

Before closing the terminal box, please check that:

- All terminal connections are tightly fitted.
- The interior is clean and free of foreign bodies.
- Unused cable entries are closed and screw plugs are tightened.
- The sealing is correctly inserted in the cover of the terminal box; check proper condition of all sealing surfaces so that the demands of the protection category are fulfilled.

Motor protection

Provide for adequate motor protective equipment in order to protect the motor from overload (e.g. motor protection switch with thermal overcurrent release).

Connect the ground wire to the marked earth screw in accordance with VDE 0100.

ATTENTION

Fuses do not protect the motor!

PRODUCT DESCRIPTION

Control C409.2 Pro+

Among other things, the control enable the proportional dosing via analogue signals 4 ... 20 mA or contact signals with the possibility of pulse division or pulse multiplication.

The graphical display shows information about the current status of the pump.

A connection for flow monitoring or flow rate measurement and an „empty“ signal with pre-alarm and dry run alarm are available as standard.

INTERFACE MODULE (13) (accessories C409.2)

The INTERFACE MODULE provides level input, PROFIBUS connectivity (see TM05) and PROFINET connectivity (see TM07).

Stroke frequency transmitter (16) (option RF409.2)

sera pumps R(F)/M(F)409.2 /R(F)/M(F)410.2 are oscillating displacement pumps with an exactly defined stroke volume per each pump stroke.

If these dosing pumps should be used for automatic filling processes or charge dosing, then the single pump strokes must be determined and converted into electrical signals.

For this purpose, a stroke frequency transmitter (inductive contactor) is added to the pump (the option cannot mounted additionally) and reports each single pump stroke to the evaluation unit (e.g. preselection counter, SPC-control unit, etc.).

Technical data	
Rated voltage	10 - 60 V DC
Constant current	< 200 mA
Short circuit-proof:	
Connection mode	plug connector with 2 m cable
LED (green)	indicates supply voltage
LED (yellow)	indicates switching status

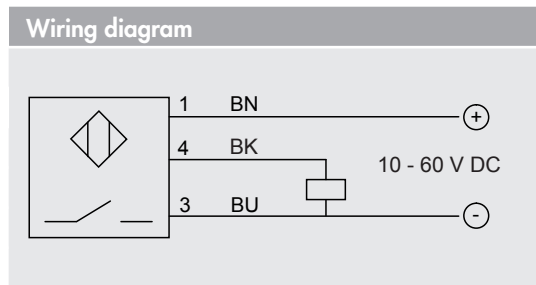

ATTENTION

When switching inductive loads (protectors, relays, etc.), surge protectors (varistors) must be fitted owing to the high self-induction voltage!

ATTENTION

When the pump is deployed in explosion-hazardous areas a NAMUR type stroke frequency transmitter (II2G EExia IIC T6, acc. to ATEX95) is to be provided!

PUMP DATA			RF 409.2-8 K	RF 409.2-12 K	RF 409.2-18 K
Permissible pressure p_{2max} at the pump outlet	bar		140	140	80
Nominal capacity QN at p_{2max}	l/h	50 Hz	8	12	18
		60 Hz	10	14	22
Quantity per stroke	ml/stroke	(100%)	1,3	1,3	3,0
Max. suction height	mWC		3	3	3
Min./max. permissible pressure at the pump inlet	bar	$p_{1min/max}$	-0,3/0	-0,3/0	-0,3/0
Recommended nominal diameter DN of the connecting pipes	mm		8	8	8
Nominal stroke frequency	1/min	50 Hz	100	150	100
		60 Hz	120	180	120
Weight approx	kg		12	12	12

The nominal data refer to water, 20°C and nominal pressure. With lower counterpressure it can come to be soaked off achievements.

ELECTRICAL DATA		RF 409.2-... K
Power consumption	kW	0,37
Voltage	V	230/400V 50Hz, 460V 60Hz
Frequency	Hz	50/60
Protection category	IP	55

i NOTE

The motor data can be read off the type plate on the drive motor of the respective pump!

NOISE MEASUREMENT

Max. sound pressure at max. burden 50 - 65 dB(A)

VISCOSITY, PUMPED MEDIUM

Max. viscosity with non-spring-loaded valves 100 mPas (=cP)

TEMPERATURE DATA

Max. liquid temperature 60 °C

Min. liquid temperature 10 °C

Max. operating temperature 40 °C

Min. operating temperature 0 °C

Max. storage temperature 40 °C

Min. storage temperature 0 °C

TECHNICAL DATA

AMBIENT CONDITIONS	
Max. installation altitude above sea level	1000 m
Max. relative air humidity	< 90%

Dimensions RF409.2... K standard

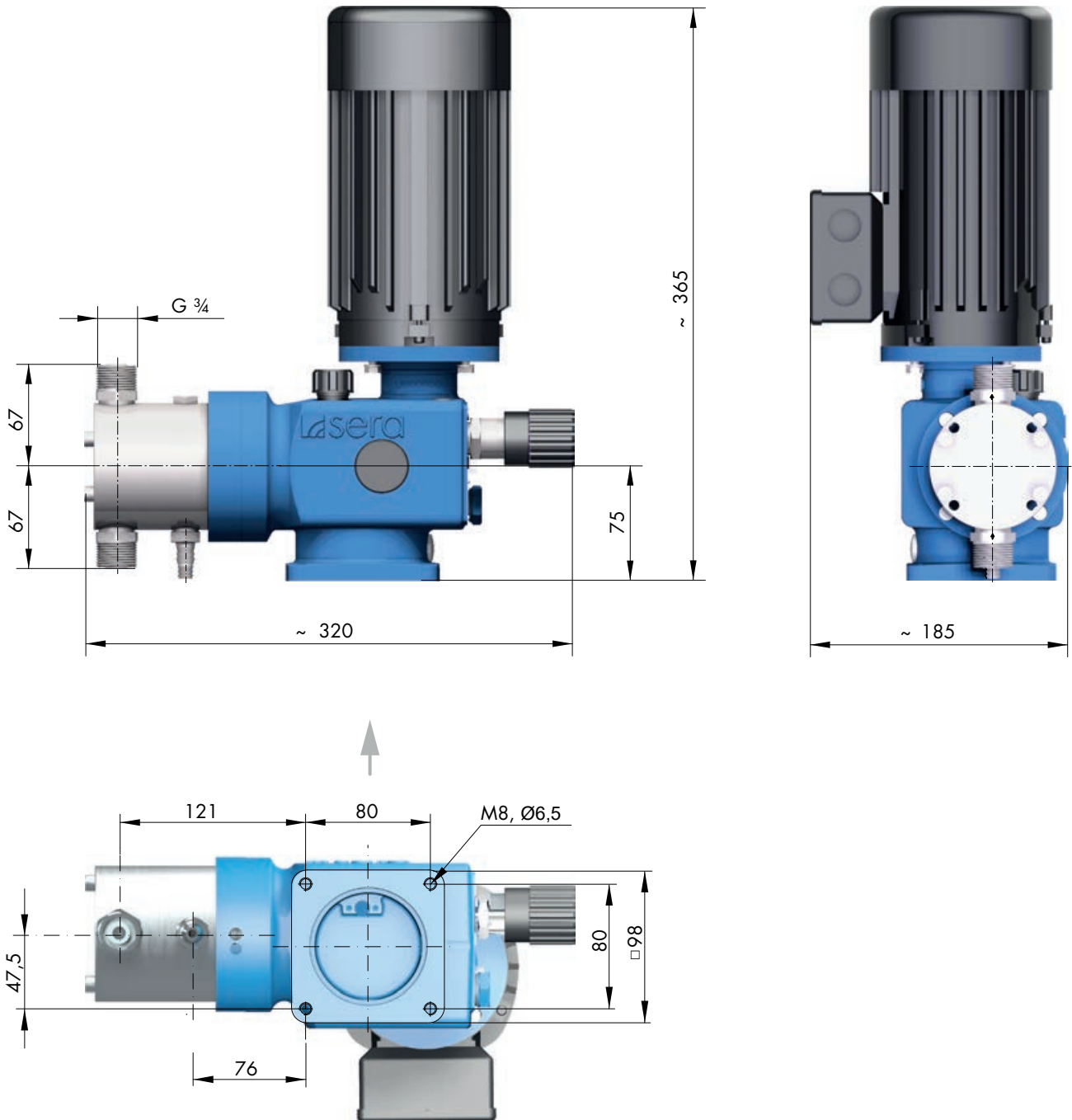

Dimensions C409.2... K standard

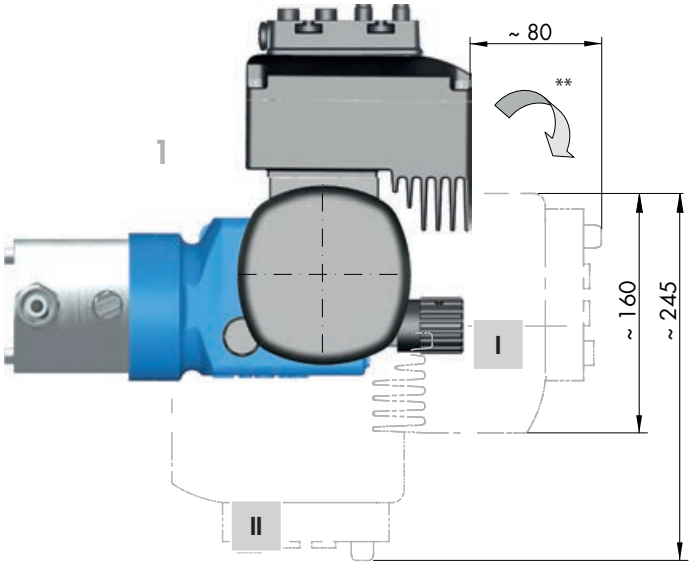
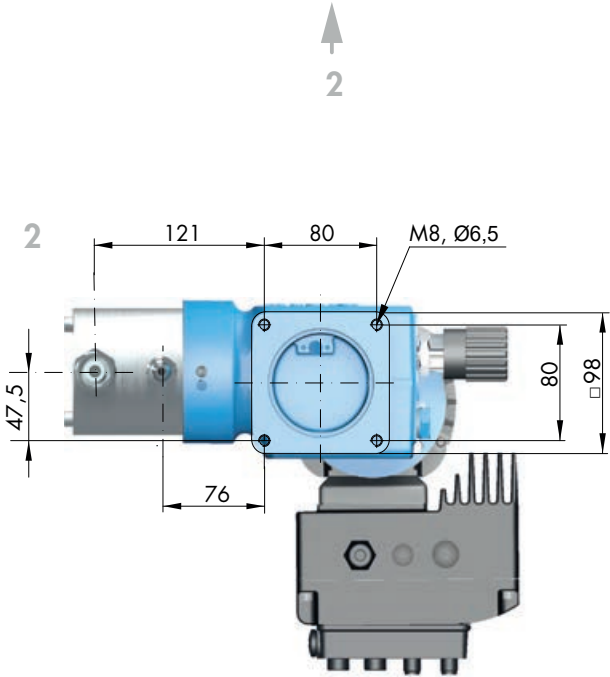
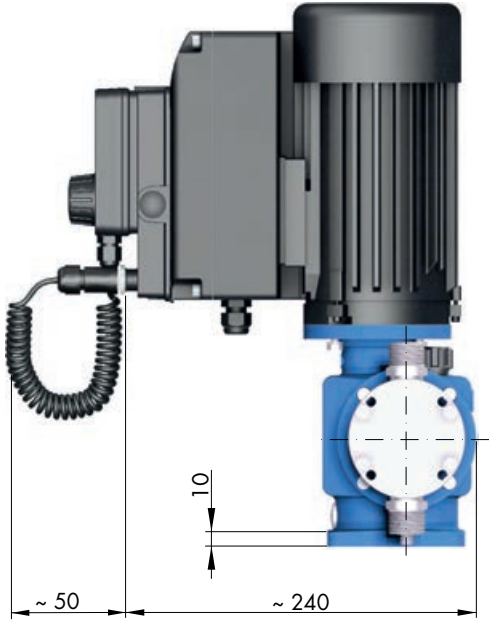
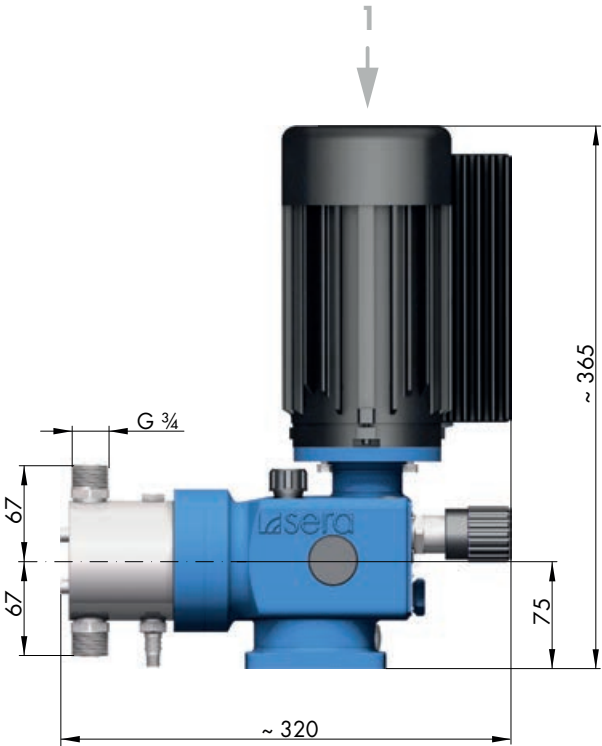

TECHNICAL DATA

Dimensions ...409.2 options

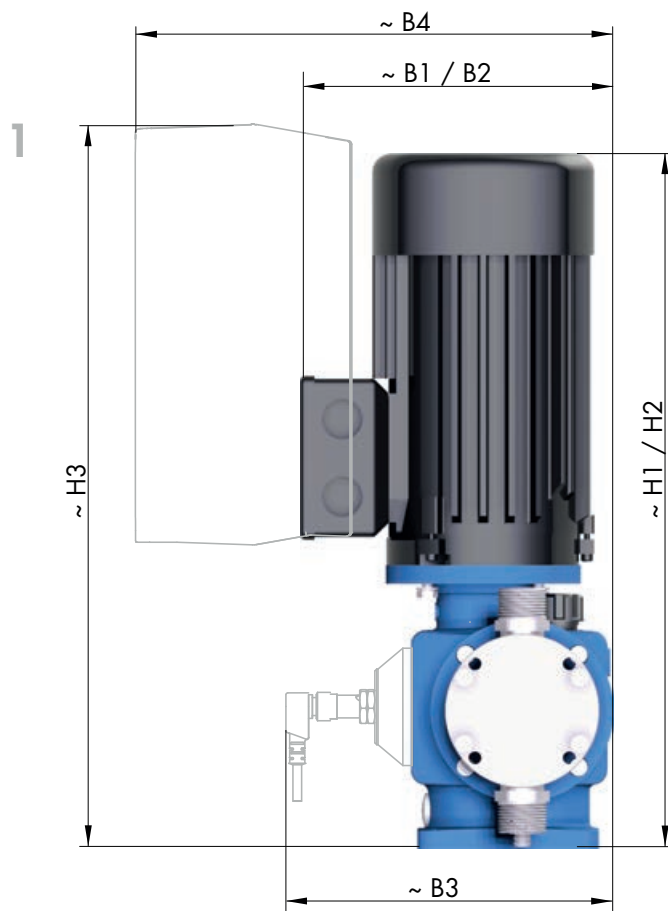
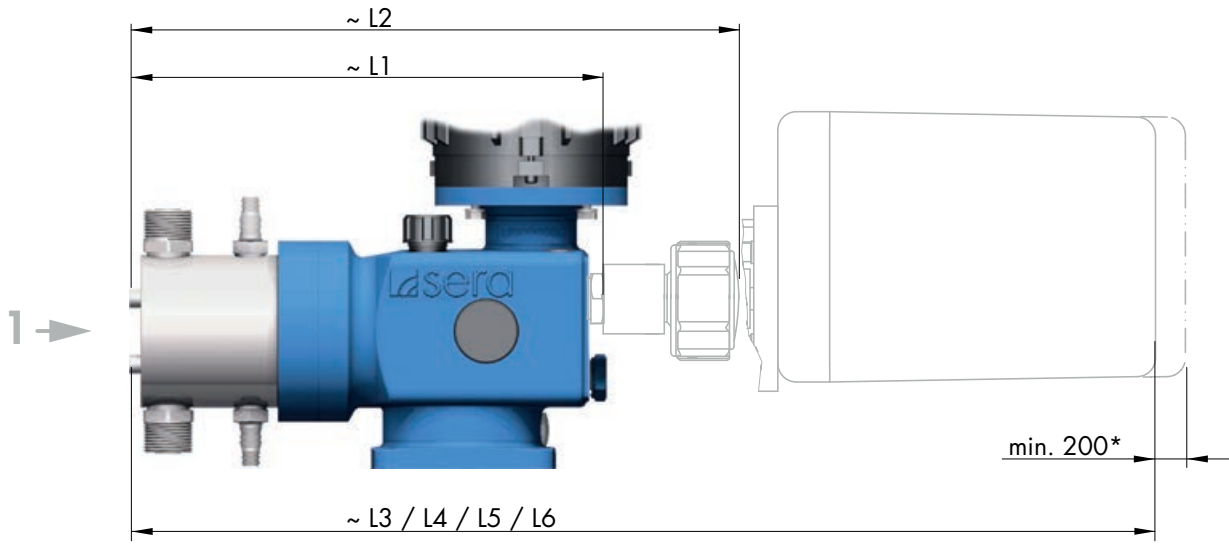

* for removing the actuator cover

OPTIONS				
MAX. TOTAL HEIGHT		... 409.2-8 K	... 409.2-12 K	... 409.2-18 K
H1	with AC motor	365	365	365
H2	with motor ATEX	420	420	420
H3	with frequency converter	410	410	410
MAX. TOTAL WIDTH				
B1	with AC motor	200	200	200
B2	with motor ATEX	220	220	220
B3	with stroke freq. transmitter	175	175	175
B4	with frequency converter	260	260	260
MAX. TOTAL LENGTH				
L1	mit blind plug (M(F)...))	260	260	260
L2	HLV with position indicator	365	365	365
L3	HLV with actuator	495	495	495
L4	HLV with actuator with integrated positioner	575	575	575
L5	HLV with actuator ATEX	665	665	665
L6	HLV with pneumatic actuator	625	625	625

HLV ► Manual stroke length adjustment
(Measurements in mm)

Dimensions C409.2... K options

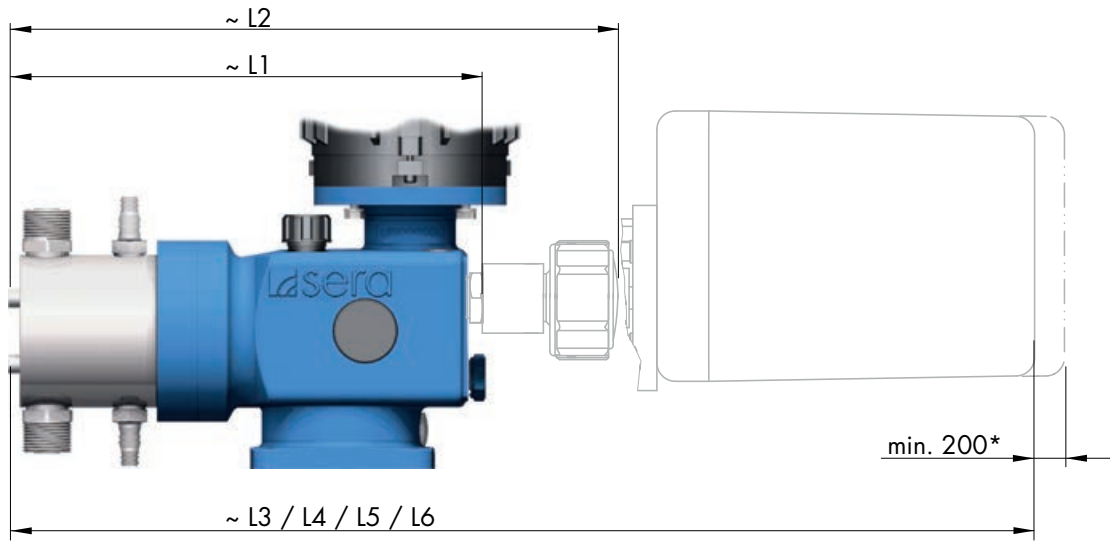

* for removing the actuator cover

OPTIONS		RF 409.2-8 K	RF 409.2-12 K	RF 409.2-18 K
L1	mit blind plug (M(F)...)	260	260	260
L2	HLV with position indicator	365	365	365
L3	HLV with actuator	495	495	495
L4	HLV with actuator with integrated positioner	575	575	575
L5	HLV with actuator ATEX	665	665	665
L6	HLV with pneumatic actuator	625	625	625

HLV ► Manual stroke length adjustment
(Measurements in mm)

* for removing the actuator cover

WARNING

Observe and follow the safety instructions by all means.
See the additional instructions „SAFETY INSTRUCTIONS“.
Man, machine and environment are endangered if the safety instructions are not observed.



NOTE

Pump design data for dosing and its temperature can be found in the order confirmation.

NOTE

Operating conditions:
Ambient temperature, relative air humidity and max. installation altitude ► see chapter „Technical data“.

- The standard model of the pump is only approved for installation in dry areas in a non-aggressive atmosphere.
- Protect the pump from heat sources, direct sunlight and UV light.
- See “Dimensions” chapter for dimensions of the pump connections and fixing holes.
- Fixing the pump with at least four bolts above the pump base is required for safe operation.
- Install the pump so that there is no vibration and no tension and that it is aligned precisely.
- Install the pump at the optimum possible operating height. Mount the pump so that the valves are vertical.
- Ensure that there is sufficient space around the pump body and the suction and pressure valve so that these parts can be easily dismantled if required.
- Design the nominal diameters of the downstream piping and the valves installed in the system to be the same size or larger than the nominal inlet and outlet diameters of the pump.
- To check the pressure ratios in the piping system, it is recommended to provide connections for pressure measurement fittings (e.g. manometers) near the suction and pressure ports.
- Drain valves must be provided.
- Before connecting the pipes, remove the plastic caps on the suction and pressure ports of the pump.
- Check the fastening bolts for the pump body for tightness and tighten if necessary, see chapter “Overview of the tightening torques”.
- Connect pipes to the pump so that there are no forces acting on the pump, such as e.g. misalignment, weight or strain of the pipe.
- Keep the suction pipes as short as possible.
- Use pressure and medium resistant hoses / pipes.
- All pipes and containers connected to the pump must comply with the regulations and must be cleaned, tension-free and intact.
- Display devices must be easily accessible and readable.

In order to avoid cavitation, overload or excessive delivery, the following points should be noted:

- Avoid high suction heights.
- Keep pipes as short as possible.
- Select sufficiently large nominal diameters.
- Avoid unnecessary choke points.
- Install a pulsation damper.
- Install overpressure protection.
- Install a pressure-sustaining valve, if necessary
- Provide feed line for outgassing media.

WARNING

The pump with a control is only designed for operation outside Ex-zonest!

SUCTION SIDE (1)

The following fittings can be used on the suction side:

1.1 Line strainer



1.2 Suction aid
Siphon vessel



1.3 Suction lance



1.4 Multifunction device



1.5 Foot valve



1.6 Shut-off valve



PRESSURE SIDE (2)

The following fittings can be used on the pressure side:

2.1 Vent valve



2.2 Injection fitting



2.3 Dosing valve



2.4 Pulsation damper



2.5 Diaphragm pressure keeping valve



2.6 Diaphragm relief valve



2.7 Multifunction valve



2.8 Flow meter ⁽¹⁾

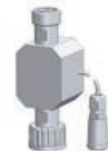

2.9 Flow monitor ⁽¹⁾



2.10 Shut-off valve



⁽¹⁾ only for diaphragm pumps with a control

SUCTION SIDE (1)

Line strainer (1.1)

Connect suction line slightly above the bottom of the tank and install a line strainer (0.1 – 0.5 mm mesh size – depending on valve nominal diameter of the pump).



ATTENTION

If impurities are not removed, this results in malfunctions of the pump and the system.

Suction aid / siphon vessel (1.2)

For high tanks without connection on the bottom of the tank ► install suction aid / siphon vessel. Thereby, pay attention to accelerating pressures which may be generated in a long suction pipe.

Suction lance (1.3)

Install a suction lance for removal of chemicals from tanks and barrels.
The integrated foot valve prevents the backflow of the suctioned medium.
The suction lances are equipped with a level switch for „empty“ signal.

Multifunction device (1.4)

The multifunction device is installed in the suction side piping of the pump and is used for determination of the delivery rate of pumps under real operating conditions.
The device can be filled either using a pending tank volume (communicating container) or using a hand vacuum pump.

Foot valve (1.5)

To prevent running dry of the suction line ► install foot valve (check valve) at the end of the suction line.

PRESSURE SIDE (2)

Vent valve (2.1)

If air can be drawn in due to falling liquid level in the suction tank and at the same time delivered to a pressurised line or against a pressure-sustaining valve ► install vent valve in the pressure line.

NOTE

The delivery flow can be interrupted if there is air in the suction line!

Injection fitting (2.2)

Install an injection fitting that routes into a main line to prevent the backflow of the pumped medium in the dosing line.

WARNING

Unwanted mixing in the dosing line occurs if any possible backflow from the main line is not prevented.

Dosing valve (2.3)

Installation of the dosing valve prevents the liquid from the system to be treated being able to penetrate into the dosing line.

Pulsation damper (2.4)

Damping of the pulsation by installation of pulsation dampers if:

- a low-pulsation delivery flow is desired for process reasons,
- acceleration forces caused by the piping geometry must be removed.

Install pulsation damper as close as possible to the pump head.

If both pulsation damper and pressure-sustaining valve should be integrated, install the pressure-sustaining valve between pump and pulsation damper.

WARNING

Undamped acceleration forces can result in the following faults / damage:

- flow rate fluctuations
- dosing errors
- pressure surges
- valve shocks
- increased wear on the suction and pressure sides of the pump
- mechanical destruction of the pump
- leaks and valve shocks if the permissible maximum pressure on the pump pressure side is exceeded
- damage to the piping and its installed fittings

Diaphragm pressure-keeping valve (2.5)

If dosing into a main line with negative pressure ► install pressure-keeping valve in the dosing line.

ATTENTION

It must be ensured during the installation that excess delivery (due to positive pressure difference ($\geq > 1$ bar) between pressure and suction sides) is avoided.

Diaphragm relief valve (2.6)

If the permissible pressure in the system can be exceeded by closing any shut-off valve or by clogging of the line ► install diaphragm relief valve.

When using an external overflow valve, the following is applicable for the return line:

- Route the return line sloping downward into the storage tank which is under atmospheric pressure or into an open drainage channel.
- Or connect directly to the pump suction line, but only if there is no check valve in the suction line (e.g. foot valve of a suction lance).

ATTENTION

Shut-off valves must not be closed when the pump is running!

WARNING

An overpressure protection device (e.g. relief valve) must generally be provided if the permissible operating pressure can be exceeded.

ATTENTION

If the permissible operating pressure is exceeded and the pump is not equipped with overpressure protection, the pump will be damaged.

WARNING

The pumped medium can spray out if the pump is damaged.

Multifunction valve (2.7)

The multifunction valve provides the following functions:

- pressure-keeping valve function,
- overflow valve function,
- pressure relief function,
- venting.

The multifunction valve is mounted directly on the pump pressure port.

Flow meter (2.8)

For measurement and monitoring of the flow rate ► install flow meter.

The application range is restricted to media that are similar to water.

The flow meter is screwed upright on the pressure port of the pump and connected to the pump electronics via the input for flow monitoring.

Flow monitor (2.9)

To record the flow rate of the pump ► install flow monitor.

The application range is restricted to media that are similar to water.

The flow monitor is screwed upright on the suction port of the pump and connected to the pump electronics via the input for flow monitoring.

Operation in Ex-zone C409.2

WARNING

The pump with a control is only designed for operation outside Ex-zones!

Operation in Ex-zone R/M 409.2

WARNING

The prerequisite for the use in explosion-hazardous areas is an appropriate design of the pump.

The product supplied by **sera** meets the requirements of directive 2014/34/EU if it is correspondingly marked. This guarantees safe operation in explosion-hazardous areas.

WARNING

It is the operator's task to define the field of application and to check whether the pump is suited for this application. He/she must clearly define the zone, the device category, the explosion group and the temperature class.

WARNING

Avoid build up electrostatic conditions!

WARNING

To avoid contamination of the valves strainers in the suction line have to be installed!

Identification

The pump has a label stating the zone/device category /explosion group/temperature class in compliance with directive 2014/34/EU.

 II2G Ex h IIB T4 resp.

 II2G Ex h IIC T4
(note special specifications in the confirmation of order.)

Installation

The intended operating conditions in explosion-hazardous areas according to directive 2014/34/EU are stated in the confirmation of order or the product description. The indicated limit values should not be fallen below or exceeded. Installation regulations given in the operating instructions must be adhered to.

WARNING

Use only suitable tools for performing assembly and maintenance work on machines or plants in explosion-hazardous areas. Directive 99/92/EC must be observed.

Potential equalization

After mounting the pump the proper connection to the site potential equalization is to be ensured. The max. bleed resistor (1M Ω) has to be checked and documented.

Start-up

After installation, the pump must immediately be used for the suction of fluids, i.e. the pump must immediately be started after the tank has been installed and filled.

Operation

The intended operating conditions in explosion-hazardous areas according to directive 2014/34/EU are stated in the confirmation of order or the product description. The indicated limit values should not be fallen below or exceeded. Details about explosion zone, device category, explosion group and temperature class can be seen from the Declaration of Conformity.

Degassing of the pumped medium:

- Never let the pump run dry.
- Check the liquid level in the tank during operation of the pump.
- Make sure that the pump is switched off when the liquid level in the tank falls below the minimum level required (explosive atmosphere may be carried over)..

Vapour bubbles from the pumped medium are harmless as they have no explosive potential.



WARNING

Formation of an explosive gas mixture must be prevented.

Temperature indications

Permissible ambient temperature: $-10^{\circ}\text{C} \leq T_a \leq +40^{\circ}\text{C}$

Maintenance

The maintenance notes listed in Chapter 10 are generally applicable. **Exception:**



ATTENTION

The oil level in the stroke mechanism of the pump must be checked once a week!



WARNING

Observe and follow the safety instructions by all means.
See the additional instructions „SAFETY INSTRUCTIONS“.
Man, machine and environment are endangered if the safety instructions are not observed.



Adequate fastening at the pump foot and compliance with the operating parameters specified in the technical data are required for the operation of the pump.

Checks before every start-up:

- Check all connections for tightness.
- Tighten fixing bolts of the pump body with the specified tightening torques (see „Overview of the tightening torques“ chapter).
- Check of the electrical connections.
- Check of the mains voltage on the rating plate with the local conditions.

Driving motor

Preconditions:

- Make sure that voltage and frequency correspond with the indications on the type plate of the motor.
Permissible voltage tolerance (DIN VDE 0530).
- For rated voltage ► + 10 %
- For rated voltage range ► ± 5 %
- The connecting cable must be dimensioned according to the motor characteristics.
- Secure connecting cable with a strain relief.
- The nominal motor power refers to an ambient temperature and an installation site ► see chapter „TECHNICAL DATA“ .
Motor output will be reduced if these values are exceeded (see VDE 0530).
- Adapted for “moderate” groupe of climates according to IEC 721-2-1.

i NOTE

Operating voltage range see chapter „TECHNICAL DATA“.

i NOTE**Pump without control:**

Motor connection see chapter „Drive motor“ in the PRODUCT DESCRIPTION.

i NOTE**Pump with a control:**

Electrical interfaces see the additional operation instructions for the CONTROL.

 ATTENTION**Pump with a control:**

The pump restarts in the selected operating mode with the specified parameters after switching on again or after restoration of the power supply following a power failure.



WARNING

Observe and follow the safety instructions by all means.
See the additional instructions „SAFETY INSTRUCTIONS“.
Man, machine and environment are endangered if the safety instructions are not observed.



Check the following at regular intervals:

- Tight fit of piping.
- Tight fit of pressure and suction valve.
- Proper condition of the electrical connections.
- Tight fit of the screws for fastening the pump body (check this at least every three months).
- For the tightening torques of the mounting screws, please see Chapter „Overview of the tightening torques“.
- Additionally with motor pumps: Check oil level regularly (oil eye).

Drive motor

The electric motor should always be kept clean so that neither dust, dirt, oil nor other contaminants may affect the correct operation.

In addition, we recommend to ensure that:

- The motor does not produce strong vibrations
- Suction and blowing openings for the supply of cooling air are not closed or restricted (may lead to unnecessary high temperatures in the windings)

The ball bearings inserted in the motor are lubricated for life.

Oil change

Check oil level at regular intervals (oil sight glass (1))

Perform an oil change once a year.

To do so, proceed as follows:

- Unscrew the venting screw (5).
- Prepare an appropriate container (2).
- Open the screw plug (3) and drain off oil.
- Close hole with screw plug (pay attention to the sealing ring (4)!).
- Fill oil in threaded hole of the venting screw.
- Screw in venting screw (5).

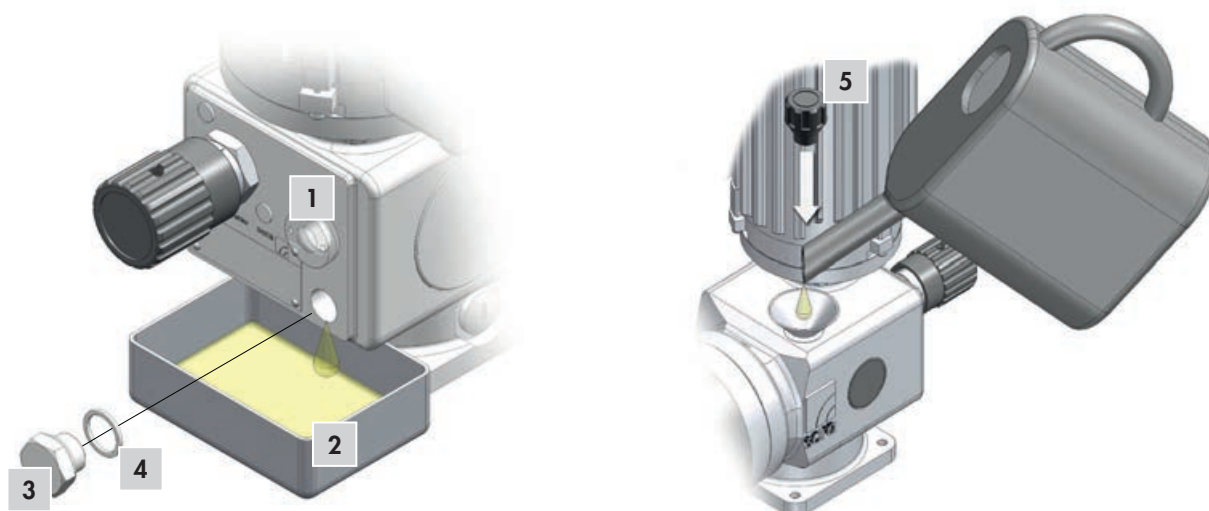

Pump type	Specification	Gear oil	sera use	Quantity (litres)
...409.2	CLP VG220 DIN51517-3	Castrol Alpha EP 220		0,3

Overview of the tightening torques



TIGHTENING TORQUES OF THE FIXING SCREWS (1)

...409.2- ... K

8 Nm

Changing the piston seal and protective diaphragm

In order to ensure a correct function of the pump and to fulfil the required safety and protective provisions it is absolutely necessary to check and replace the diaphragm at regular intervals.

- Loosen the connections on the suction- and pressure side.
- Loosen the leaking nozzles and pipe connections at the rinsing connection, if installed.
- Set the stroke length adjustment to a stroke length of 0% (front position).
- Loosen fixing screws (1) on the pump body (2).
- Remove pump body to the front.

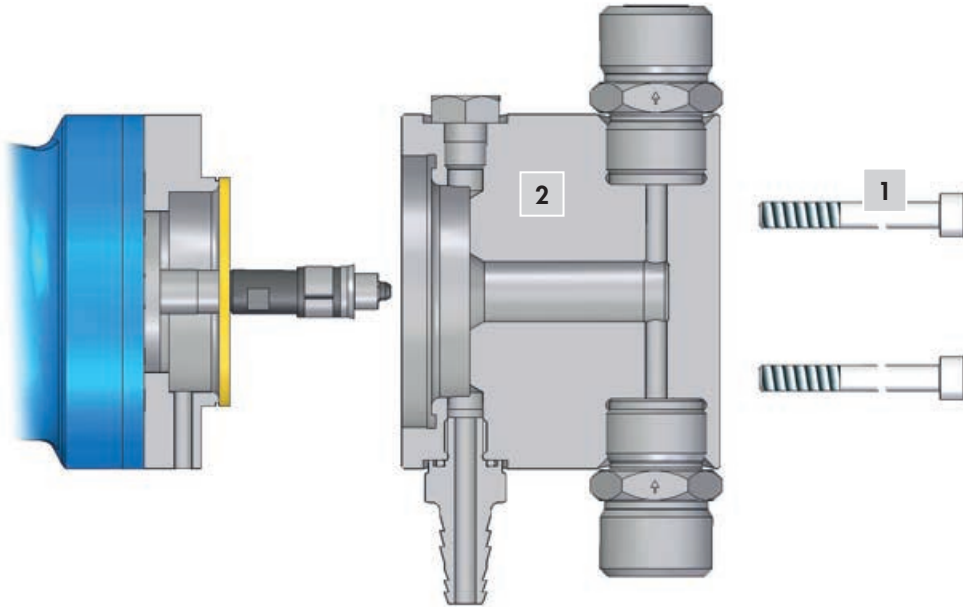

- Remove piston (3) out of the connecting rod (4).
- Pull protective diaphragm (5) off the piston.

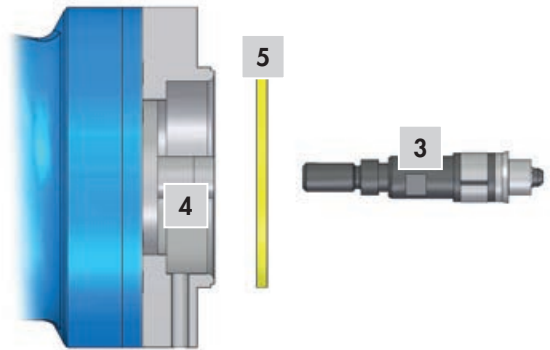

- Remove locking ring (6).
- Pull support ring (7) off the piston (3).
- Pull of piston seal (8) (piston V-sealing ring) and exchange.
- Replace piston guide ring (9).
- Replace protective diaphragm.

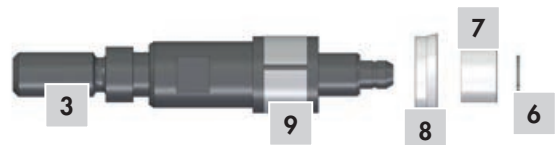

Assemble the pump in reversed order

- Make sure that the open side of the piston seal is always pointing towards the pressure- or medium side when the pump is assembled.

- Set the stroke length to 50%. Move protective diaphragm to the base ring – the diaphragm must be in the middle position.
- If the pump is not equipped with a stroke length adjustment (M-design), move the diaphragm to the middle position by turning the fan blade of the drive motor.
- When assembling the pump body, please note: suction valve below, pressure valve above!
- Observe the tightening torques (see Chapter „Overview of the tightening torques“).

Add the suction and pressure line and connect pump to the power supply. The piston pump is then again ready for operation.

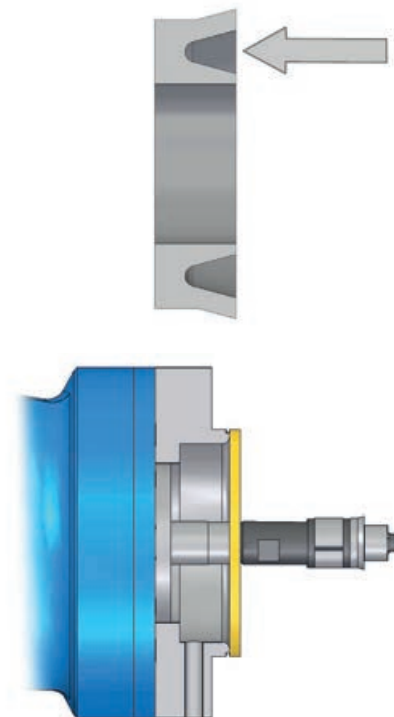

Spare and wearing parts

The following parts are considered as wearing parts of the pump:

- Protective diaphragm
- Piston seal
- Valve kit (including O-ring kit)
- O-ring kit

Depending on their use and period of use, wearing parts must be replaced at regular intervals in order to ensure a safe function of the pump.

We recommend to replace the wearing parts after 3000 operating hours or at least once a year.

A worn-out seal may result in damage to the pump body.

The following parts are considered as spare parts of the pump:

- Pump body kit (including mounting kit)
- Mounting kit

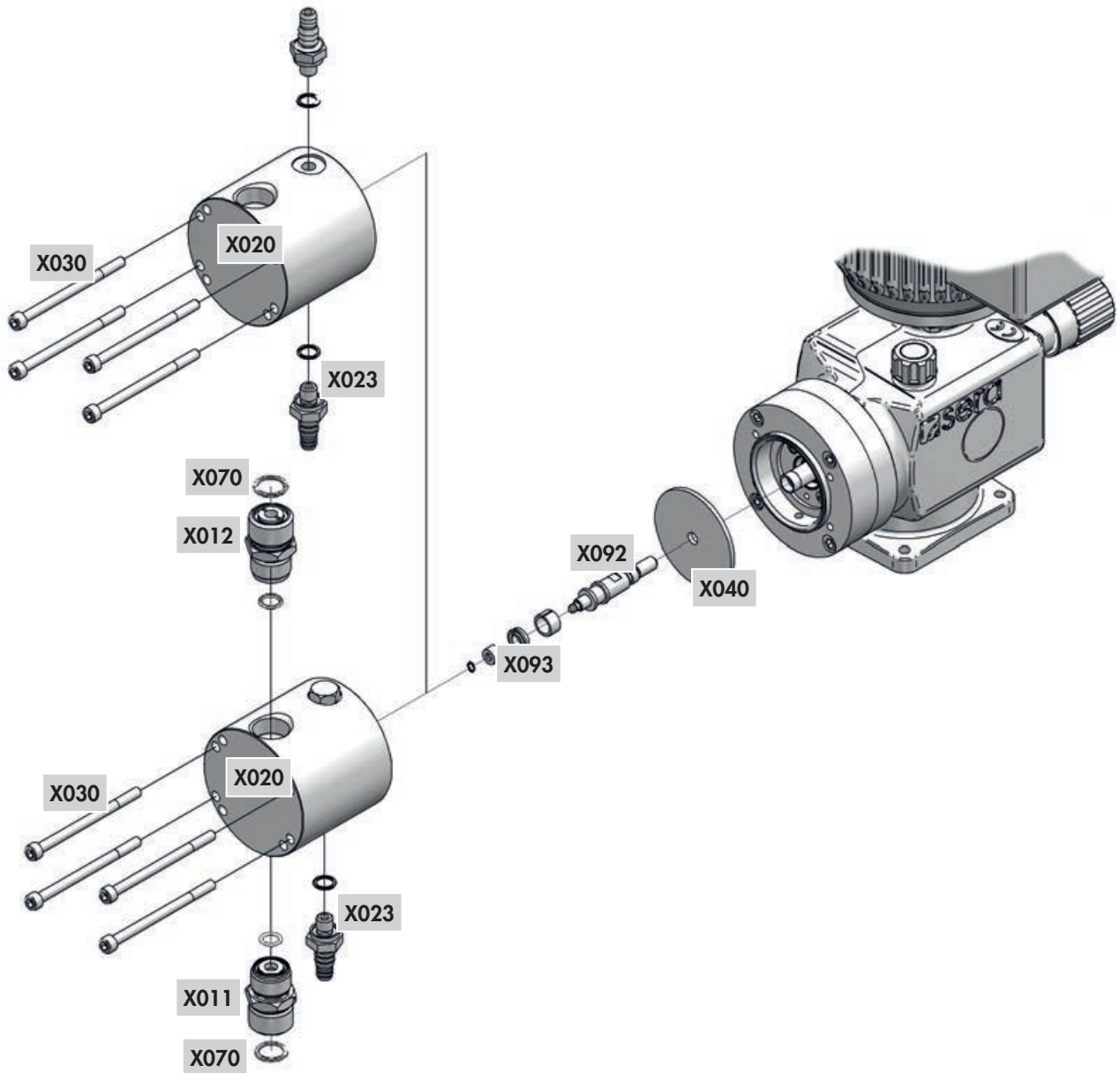

Pos.	Kit	Materials	consisting of
X011	Suction valve	1.4571	Suction valve O-rings X070
X012	Pressure valve	1.4571	Pressure valve O-rings X070
X020	Pump body	1.4571	Pump body Mounting X030
X023	Leaking nozzle		Leaking nozzle O-ring
X030	Mounting		Screws, complete
X040	Protective diaphragm		Protective diaphragm Mounting (X030)
X070	O-rings		
X092	Piston		Piston
X093	Parts kit piston		Piston guide ring Piston seal Support ring Locking ring
	Rinsing nozzle		Rinsing nozzle O-ring

sera products are sophisticated technical products which are only shipped after having been thoroughly tested and checked at our factory. Should there be any faults, these can be detected and rectified easily and quickly based the instructions in the tables.

i NOTE
 Analysis of the error messages in the display for the pumps with a control ► see the operation instructions of the control!

Fault type										Possible cause	Corrective action							
Corrective action!	Display, LED not lit!	► Pump with control	Motor does not start!	► diaphragm pump	Damage to stroke mechanism / drive!	Pump does not draw in!	Pump does not deliver!	Flow rate is not reached!	Delivery head is not reached!	Flow rate fluctuates!	Maximum permissible flow rate exceeded!	Pipe oscillates heavily!	Too high noise development!	Service life of the drive diaphragm too low!	Drive is overloaded (periodically occurring noises)!	Leakage on pump head!		
			■	■	■												Suction height too high.	Reduce suction height or suction resistance.
			■	■	■					■							Suction pipe leaking.	Check seals, tighten pipe connections.
			■	■									■	■	■		Shut-off valves in piping closed.	Open shut-off valves or check opening state ► check pump for possible damage.
			■	■	■												No pumped medium in storage tank.	Fill storage tank.
			■	■	■	■	■										Pump valves leaking.	Remove and clean valves.
			■	■		■	■										Pump valves (ball seats) damaged.	Remove and clean valves, check function; replace valves if necessary.
			■	■													Pump valves incorrectly mounted or valve balls missing.	Check installation position and completeness ► replace missing parts or install correctly.
			■	■	■		■										Filter in suction line clogged.	Clean filter.
			■	■	■	■	■								■		Electrical data of the pump do not match mains data.	Check order data. Check electrical installation. Adjust motor to the network on site (for diaphragm pumps).
				■	■	■	■			■			■	■	■		Backpressure too high.	Measure pressure with manometer directly above pressure valve if possible and compare with permissible backpressure.
			■	■	■	■	■										Foreign matter in the pump valves.	Remove and clean valves.
								■	■								Pressure on suction side higher than at the end of the pressure pipe.	Check geodetic conditions, install float valve or pressure keeping valve if necessary.
					■	■	■			■	■	■	■	■	■		Acceleration height too high due to pipe geometry.	Check acceleration height on suction and pressure sides with manometer and compare with design data ► install a pulsation damper if necessary.
														■	■		Materials coming into contact with the medium not suitable for the pumped medium.	Check whether the pumped medium matches the design data and select other materials if necessary.

FAULT ANALYSIS / CORRECTIVE ACTION

Fault type										Possible cause	Corrective action							
Corrective action!	Display, LED not lit!	► Pump with control	Motor does not start!	► diaphragm pump	Damage to stroke mechanism / drive!	Pump does not draw in!	Pump does not deliver!	Flow rate is not reached!	Delivery head is not reached!	Flow rate fluctuates!	Maximum permissible flow rate exceeded!	Pipe oscillates heavily!	Too high noise development!	Service life of the drive diaphragm too low!	Drive is overloaded (periodically occurring noises)!	Leakage on pump head!		
						■		■	■	■							Viscosity of the pumped medium too high.	Check viscosity of the pumped medium and compare with design data ► reduce concentration or increase temperature if necessary.
							■	■		■							Pumped medium is outgassing in the suction pipe and/or the pump body.	Check geodetic conditions and compare with data of the pumped medium. Operate pump with suction side supply, reduce temperature of the pumped medium.
						■											Air in suction line while pressure is present on the pressure side.	Vent pressure side.
	■																Power supply failed / switched off.	Restore power supply.
						■	■	■	■	■							Pipe connections leaking.	Tighten connections according to type of material. Be careful with plastic ► risk of fracture!!
						■	■										Pumped medium frozen in pipe.	Remove pump and check for possible damage - increase temperature of the pumped medium.
■	■						■										No mains power connection.	Connect mains power supply.
						■											Pump valves dry.	Moisten pump body and valves. Open vent valve.
						■	■	■							■		Temperature too low.	Check flowability of the dosing medium. Temperature of the medium see „Technical data“.
						■	■	■	■	■				■	■		Diaphragm rupture.	Replace the diaphragm according to the descriptions in Chapter „Replacing the diaphragm“.
■																	Reversible thermal fuse of the pump has tripped.	Let temperature of the pump cool down. Check ambient temperature.
	■																Fuse in electronics blown. ► Pump with control	Return pump for repair.
						■	■	■	■								Compensating valve not adjusted to operating conditions. ► diaphragm pump KM	Set compensating valve according to operating conditions. ► diaphragm pump KM

**WARNING**

Observe and follow the safety instructions by all means.
See the additional instructions „SAFETY INSTRUCTIONS“.
Man, machine and environment are endangered if the safety instructions are not observed.

**Shut-down**

- Switch off piston diaphragm pump.
- Rinse pump head and remove pumped medium; make sure that the rinsing agent is suitable for pumped medium and pump head.

Disposal

- Shut-down system. Please see “Shut-down”.

Dismantling and transport

- Shut-down system. Please see “Shut-down”.
- Remove all fluid residues from pump body, clean thoroughly, neutralize and decontaminate.
- Package unit and ship.

**NOTE**

A clearance certificate must be filled in when systems are returned to the manufacturer.
Acceptance will be rejected if this clearance certificate is not attached.

Complete disposal

- Remove all fluid residues from unit.
- Drain off lubricants and dispose of according to regulations!
- Dismount materials and send them to a suitable waste disposal company!

CLEARANCE CERTIFICATE

i NOTE

Inspection / repair of machines and machine parts is only carried out after the clearance certificate was filled in correctly and completely by authorized and qualified personnel.

i NOTE

Acceptance will be refused if parts are returned to the manufacturer without a proper clearance certificate.

All industrial companies are obligated by the legal provisions for occupational health, e.g. the workplaces ordinances, the Ordinance on Hazardous Substances, the regulations for prevention of accidents and the environmental protection regulations such as the Waste Management Act and the German Household Water Act to protect their employees or man and the environment from detrimental effects when handling hazardous substances.

Should special safety precautions be necessary despite careful draining and cleaning of the product the necessary information are to be provided.

Machines which are operated with radioactive media shall only be inspected and/or repaired in the safety area of the owner by a **sera** specialized fitter.

The clearance certificate is part of the inspection-/repair order.
sera reserves the right to refuse acceptance of the order for other reasons.

DOWNLOAD

Clearance certificate

Or directly scan the QR code opposite:



Clearance Certificate 

RECIPIENT

sera ProDos GmbH
Wareneingang z. Hd. Abt. Service
sera Straße 1
D-34376 Immenhausen/Hessen

SENDER

Company:	<input type="text"/>	Phone:	<input type="text"/>
Contact partner:	<input type="text"/>	Fax:	<input type="text"/>
Street address:	<input type="text"/>	E-Mail:	<input type="text"/>
Postcode, City:	<input type="text"/>	Your order number:	<input type="text"/>

We confirm that we have entered the information in this clearance certificate (decontamination certificate) correctly and completely and that the returned parts have been carefully cleaned.
The parts sent in are therefore free of residues in dangerous quantities.

<input type="text"/>	<input type="text"/>	<input type="text"/>
Place, Date	Department	Signature (and company stamp)

www.sera-web.com 

© 2020 sera GmbH. Alle Rechte vorbehalten. www.sera-web.com

FOLLOW US



sera GmbH

sera-Str. 1
34376 Immenhausen
Germany
Tel. +49 5673 999 00
Fax +49 5673 999 01
info@sera-web.com
www.sera-web.com