

Operating Instructions

Product: Pulsation damper

Type: 720.1

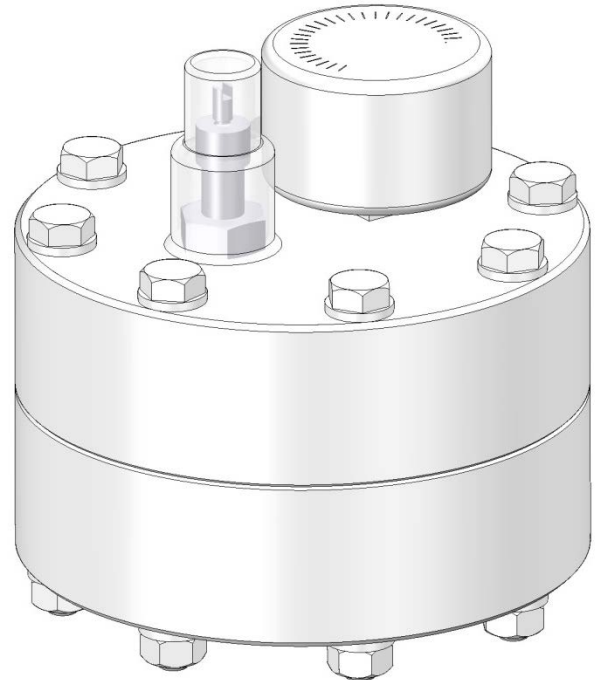

Please state here the exact type and serial number of your pulsation damper.
(can be read off the type plate on the pulsation damper)

Type:

Serial No.:

These data are important in case of queries or for ordering spare- and wearing parts and must absolutely be stated.

Manufacturer:

sera GmbH
sera-Straße 1
34376 Immenhausen
Germany
Tel. +49 5673 999-00
Fax. +49 5673 999-01
www.sera-web.com
info@sera-web.com

Translation of the original operating instructions!

Table of contents

1	General.....	3	11	Mounting instructions for diaphragm pulsation dampers - bracket.....	9
2	Types.....	3	12	Start-up	10
2.1	Type plate.....	3	13	Maintenance.....	11
2.2	Materials.....	3	14	Spare- and wearing parts	11
3	Safety instructions	3	15	Changing the diaphragm	13
3.1	Quality instructions / purpose.....	3	15.1	Tightening torques for diaphragm pulsation dampers	14
3.2	Marking of notes	4	16	Shut-down	14
3.2.1	Marking of notes in these operating instructions.....	4	17	Disposal	14
3.2.2	Marking of notes on the product.....	4	17.1	Dismantling and transport.....	14
3.3	Dangers in case of inobservance of the safety instructions	4	17.2	Complete disposal.....	14
3.4	Safety conscious working.....	4	18	Clearance Certificate.....	15
3.5	Design and service life.....	4			
3.6	Intended use	4			
3.7	Approved installation-, maintenance and operating personnel	4			
3.8	Personal protection for maintenance and service....	5			
3.9	Operating conditions of the pulsation damper	5			
4	Areas of application and function	5			
5	Checking the packaging at the place of destination	5			
6	Storage.....	5			
7	Technical specifications	6			
7.1	Dimensions.....	6			
7.2	Technical specifications	6			
8	Accessories	7			
8.1	Filling pump FLP2 for filling equipment	7			
9	Installation	7			
10	Fastening.....	8			
10.1	T piece.....	8			
10.2	Bracket	9			

Operating Instructions

1 General

Before commissioning and during operation of the pulsation damper the respective regulations valid at the place of installation are to be observed.

sera pulsation dampers are required if for procedural reasons, a pulsation-poor delivery rate is desired or, depending on the pipe geometry, unacceptable high pressure peaks are to be reduced when operating oscillating displacement pumps. This can require the installation of pulsation dampers on the suction- and pressure side.

2 Types

2.1 Type plate

Each **sera** pulsation damper is factory provided with a type plate. The following information can be found on this type plate.

sera GmbH www.sera-web.com			
Typ/type	①		
Mat./mat.	②	PS	⑤ bar
Nr./no.	③	V	⑥ L
Bj./year	④	TS min./max.	⑦ °C

Fig. 01 Type plate

Explanation of the indications on the type plate		
1	Type	Pulsation damper type
2	Mat.	Material of the pulsation damper
3	No.	Serial number of the pulsation damper
4	Bj.	Year of construction of the pulsation damper
5	PS	Maximum allowable pressure
6	V	Volume
7	TS min./max.	Allowable minimum / maximum temperature

Table 01 Explanation of type plate

2.2 Materials

The materials used are stated in the order confirmation.

3 Safety instructions

3.1 Quality instructions / purpose

Please read these operating instructions carefully before the pulsation damper is started or serviced. Observance of these operating instructions and, in particular, the safety instructions, helps to

- avoid dangers to persons, machines, and environment
- increase reliability and service life of the pulsation damper and the complete system
- reduce repair cost and downtime.

The **sera** quality management and quality assurance system for pumps, systems, and fittings is certified according to ISO 9001:2008.

sera products comply with the valid safety requirements and accident prevention regulations.

CAUTION !



Always keep these operating instructions within reach at the place of installation.

CAUTION !



Pay attention to the safety data sheet of the pumped medium! The owner must take corresponding accident prevention measures to protect operating personnel from danger through the pumped media used!

Operating Instructions

3.2 Marking of notes

3.2.1 Marking of notes in these operating instructions

Special notes in these operating instructions are marked with the general danger symbol



(safety symbol in compliance with DIN 4844 – W9)

3.2.2 Marking of notes on the product

Symbols which are directly attached to the pulsation damper, e.g. symbols for fluid connections are to be observed and kept in legible condition.

3.3 Dangers in case of inobservance of the safety instructions

Inobservance of these safety instructions can result in danger to persons, hazards to the environment and damage to the pulsation damper.

Inobservance can result in:

- Failure of important functions of the pulsation damper/system
- Inobservance of prescribed methods for maintenance and servicing
- Danger to persons through chemical influences
- Hazards to the environment through leaking dangerous media

3.4 Safety conscious working

The safety instructions specified in these operating instructions, the national regulations concerning accident prevention as well as internal working-, operating-, and safety instructions of the owner are to be observed.

3.5 Design and service life

The following points are to be observed:

- In general, the pulsation damper is designed for fluid group I, if nothing to the contrary is specified in the order confirmation.
- The service life
 - for PVC, PP is ca. 10 years if the regular checks and maintenance intervals are kept and if the wearing parts are replaced as specified. The owner is responsible that the regular checks according to 2014/68/EU are carried out.

3.6 Intended use

sera pulsation dampers are only to be deployed according to the intended purpose stated in the order confirmation.

sera does not assume any responsibility for damage resulting from an operation which does not conform with the intended use.

If the pulsation damper is to be used for other applications, then the suitability of the pulsation damper for the new operating conditions must be discussed with sera beforehand!

Criteria for proper operation of the pulsation damper:

- Max. pressure of the pulsation damper
- Observe characteristics of the pumped medium – fluid group (please see safety- and product data sheet of the pumped medium – the safety data sheet is to be provided by the supplier of the chemical)
- Resistance of the materials which come in contact with the pumped medium
- Operating conditions at the place of installation
- Temperature of the pumped medium
- Sufficient volume when the pulsation damper is operated together with oscillating displacement pumps

sera does not assume any responsibility if these criteria are not or only partly observed by the owner / operator.

CAUTION !



Secure pulsation dampers by a safety fitting which is set to the maximum permissible pressure according to the valid regulations and the directive for pressure equipment 2014/68/EU.

CAUTION !



The national regulations for pressure vessels must be taken into account!

CAUTION !



The structural design of the pulsation dampers must not be changed!

3.7 Approved installation-, maintenance and operating personnel

The system operator may only approve persons to operate or maintain the unit, who are at least eighteen years old and suitably qualified, and of a physical and mental state to perform the tasks entrusted to them. These persons must be properly instructed and act responsibly, properly and reliably. The operating personnel must be familiar with all applicable accident prevention and safety instructions and regulations.

Operating Instructions

3.8 Personal protection for maintenance and service

In order to avoid risks to health, the provisions of the German Ordinance on Hazardous Substances (GefStoffV) (§14 Safety Data Sheet) and relevant national safety regulations for the pumped medium and the operating conditions of the pulsation damper must strictly be adhered to.

CAUTION !



Wear protective clothing, gloves, and a face protecting mask.

CAUTION !



Personal protective equipment must be provided by the owner!

3.9 Operating conditions of the pulsation damper

The maximum allowable pressure depends on the operating temperature and the pumped medium. It must not be exceeded. This is applicable to normal operation as well as filling from the sera pressure measuring- and filling equipment.

CAUTION !



Do not exceed the maximum allowable pressure!

CAUTION !



For pulsation dampers the pressures according to the operating temperatures (please see Chapter 7.5) are strictly to be observed.

4 Areas of application and function

During operation of oscillating displacement pumps, pressure peaks occur. The magnitude of these peaks depends, among other things, on the pipe length and diameter as well as on the density of the pumped medium.

Depending on the system configuration, these pressure peaks may lead to cavitation on the suction side.

On the pressure side, also either excess supply or inadmissibly high loads on the system may occur.

Pulsation dampers reduce these pressure peaks and provide for a pulsation-poor flow after the pulsation damper.

With the pulsation dampers described in these instructions, the conveying medium is separated from the gas cushion by a diaphragm (pulsation damper with separating diaphragm) (see Fig. 02).

This helps to prevent that the gas is carried away by the pumped medium during operation. The chamber above the diaphragm must be precharged with oil-free air or nitrogen to a value of approx. 60% of the operating pressure to be expected (gas precharge pressure).

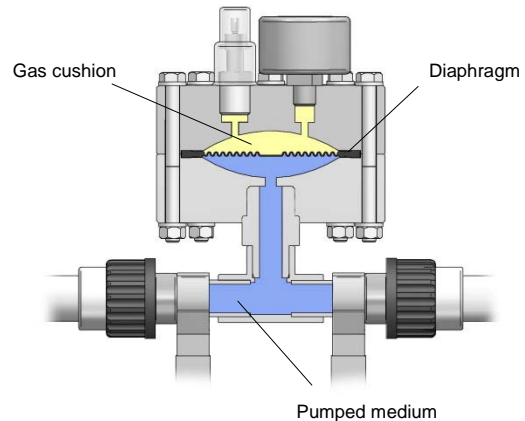

Fig. 02

CAUTION !



The damper can only work properly if the gas cushion is large enough. For this reason, always ensure that this condition is met!

5 Checking the packaging at the place of destination

On delivery, immediately check the packaging for damage. Report any external damage immediately to the transport company, and fill in a damage report. After the transport company has recorded the damage, open the package and check the contents for damage.

6 Storage

An undamaged packaging protects the unit during subsequent storage and should only be opened when the pulsation damper is installed.

Proper storage increases the service life of the pulsation damper and comprises prevention of negative influences such as heat, humidity, dust, chemicals etc.

The following storage instructions are to be observed:

- Storage place: cool, dry, dust-free and slightly ventilated
- Storage temperatures between +2°C and +40°C
- Relative air humidity not more than 50%.

If these values are exceeded, metal products should be sealed in foil and protected from condensation water with a suitable desiccant.

Do not store solvents, fuels, lubricants, chemicals, acids, disinfectants and similar in the storage room.

7 Technical specifications

7.1 Dimensions

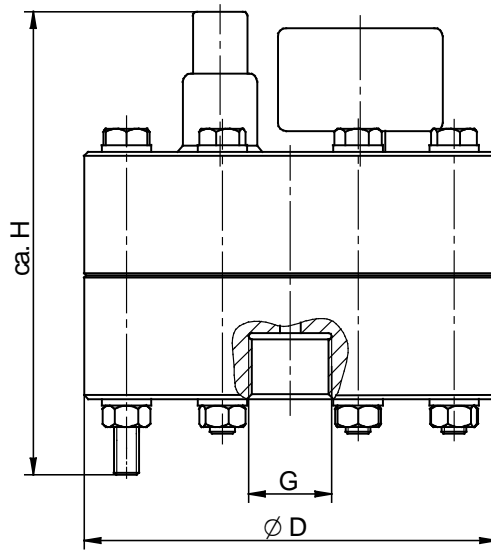

Fig. 03 Dimensions

Type	Article No.	Material		DN	G inside DIN EN ISO 228	Ø D	H	Dead weight
		Parts in contact with the medium	Diaphragm					
720.1	37601856	PP	PTFE ²⁾	5	G1/2	100	105	0.9
	37601848	PVC	PTFE ²⁾					0.9
	37601857	PVDF ¹⁾	PTFE ²⁾					1.0

Table 02 Dimensions

¹⁾ Upper part of pulsation damper made of PVC
²⁾ optional: CSM or FPM

7.2 Technical specifications

Type	Material	Max. allowable pressure PS max.	Volume V
		(bar)	(litre)
720.1	PP	10	0,025
	PVC		
	PVDF/PVC		

Table 03 Performance data

Other materials, e.g. PVDF, or performance data are stated in the order confirmation or on the type plate.

Operating conditions				
Temperature [°C] *		Max. allowable pressure (PS)		
		(bar)		
min.	max.	PP	PVC	PVDF/PVC
+2	+20	10	10	10
+2	+30	9	8	9
+2	+40	7	5	7

Table 04 Performance data

* (for water)

8 Accessories

8.1 Filling pump FLP2 for filling equipment

- Filling pressure up to 7 bar
- with pressure gauge
- 2 m hose
- Coupling piece for air filling valve

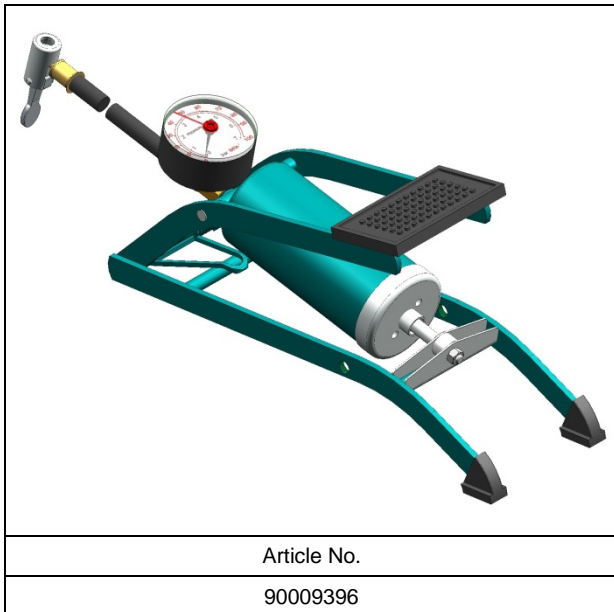

Fig. 04 / Table 05

9 Installation

The diaphragm pulsation damper is mounted on the pressure side of the pump (see Fig. 05). In principle pulsation dampers can also be installed on the suction side; in this case, however, pulsation dampers without separating diaphragm are normally used. The following is to be observed:

- Pulsation dampers are only suitable for inside use, unless otherwise specified in the order confirmation.
- Protect the dampers from direct sunlight.
- Install pulsation dampers near the pump.
- The installation position is arbitrary.

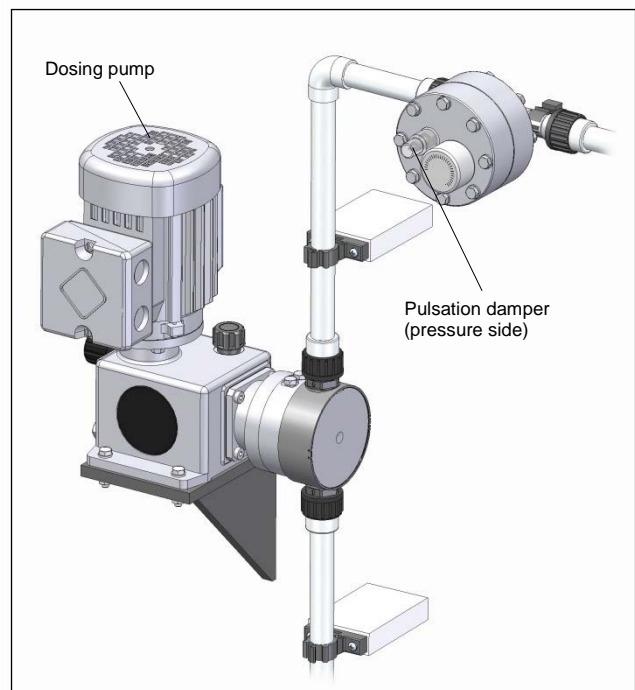

Fig. 05 Example of an installation

- Filling device or pressure measuring- and filling device must be easy to overview and operate (see Fig. 06).

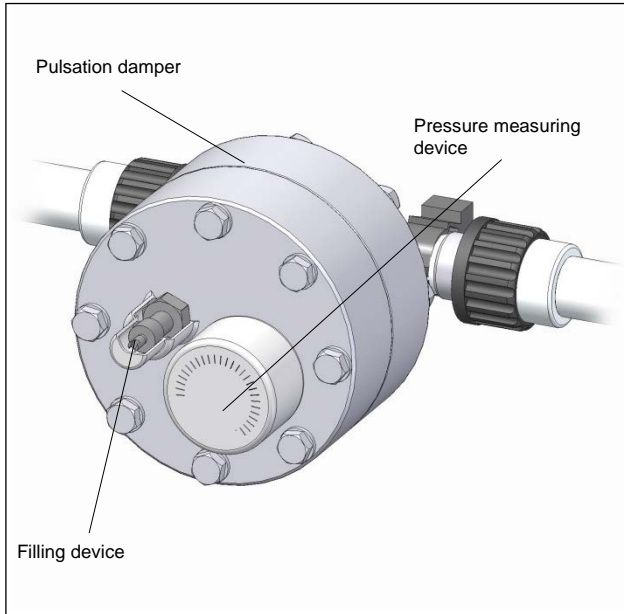
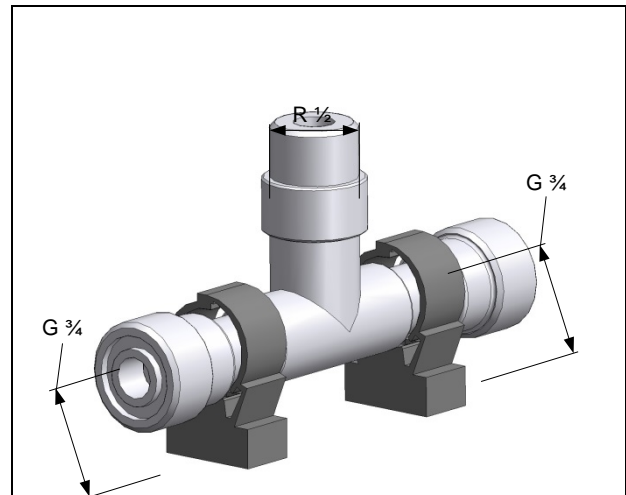

Fig. 06 Pressure measuring- and filling device

- Install the pulsation damper in the system in such a way that it is easy to access and free from vibrations.
- The attached pipes must not transmit any mechanical tensions to the pulsation damper.
- The weight of the pulsation dampers may only be applied to the pipe if the pipe is adequately dimensioned. Otherwise suitable brackets are to be used.

10 Fastening

10.1 T piece



Material		Article No.
T piece	Seal	
PVC	FPM	90021752
	EPDM	90021753
PP	FPM	90021755
	EPDM	90021756
PVDF	FPM	90021758
	EPDM	90021759

Fig. 07 / Table 06

Pulsation damper 720.1

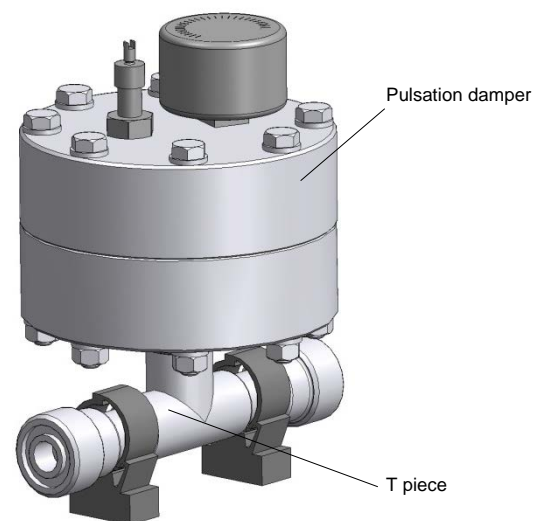

Fig. 08 Example of an application with threaded hose coupling

10.2 Bracket

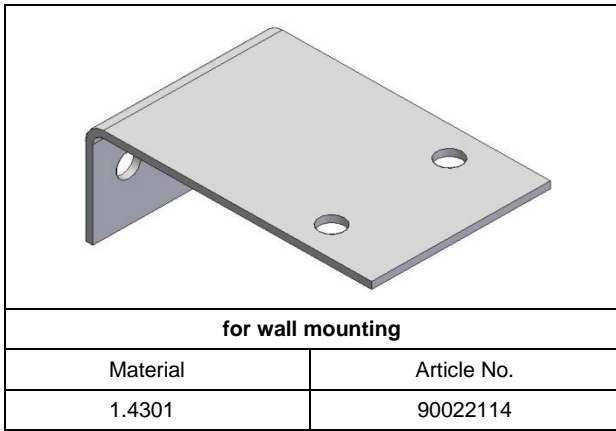

Fig. 09 / Table 07

Pulsation damper 720.1

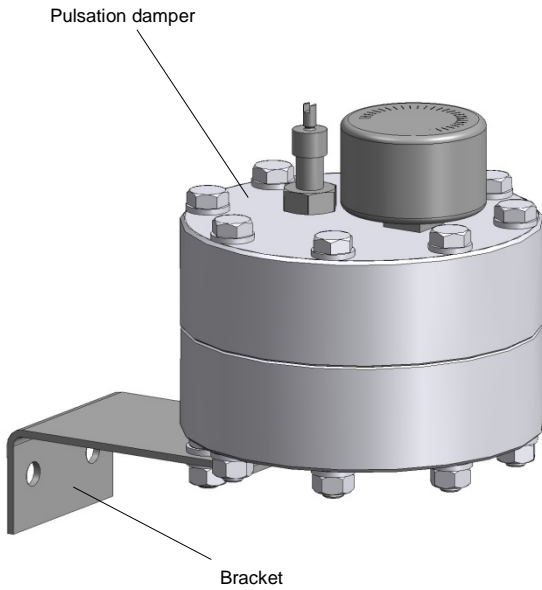

Fig. 10 Example of an application

11 Mounting instructions for diaphragm pulsation dampers - bracket

The diaphragm pulsation damper type 720.1 has two extended screws and two additional washers and nuts (see Fig. 11).

Before fastening the pulsation dampers on the bracket the outer nuts of these screws are to be loosened.

Place pulsation damper on the bracket and fasten with nuts.

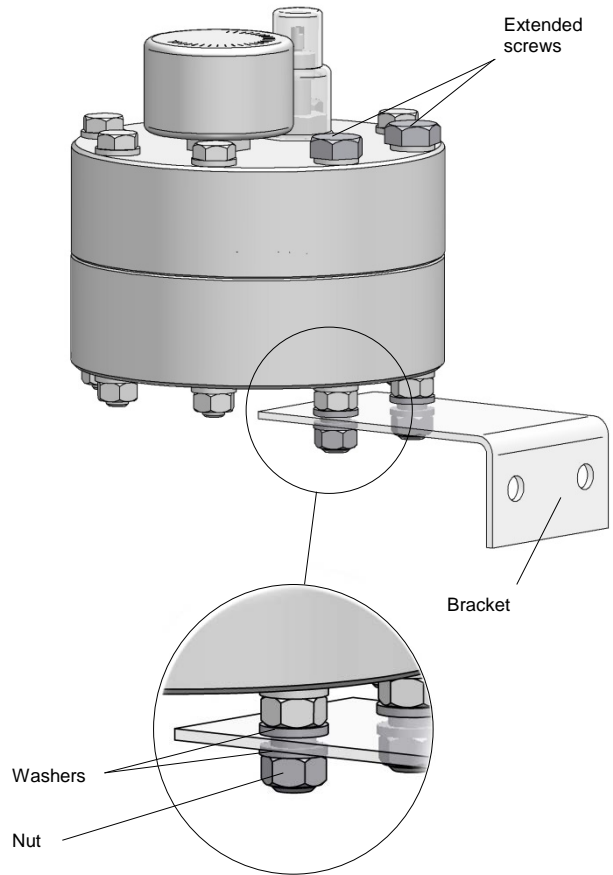

Fig. 11 Mounting instructions

12 Start-up

The **sera** diaphragm pulsation dampers are mounted on the pressure side of the pumps. Filling- and pressure measuring equipment is required for start-up of the pulsation dampers.

Filling- and pressure measuring equipment with filling valve, connection for filling pump FLP 2

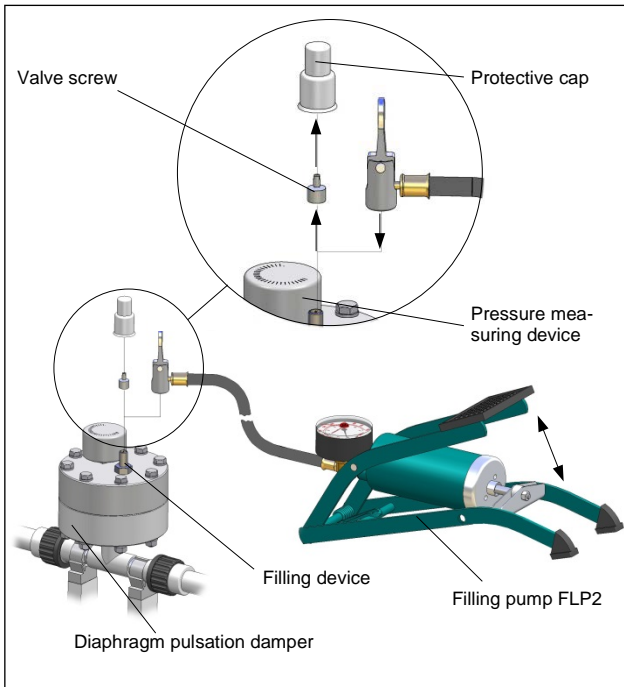

Fig. 12 Connection of the filling pump FLP2

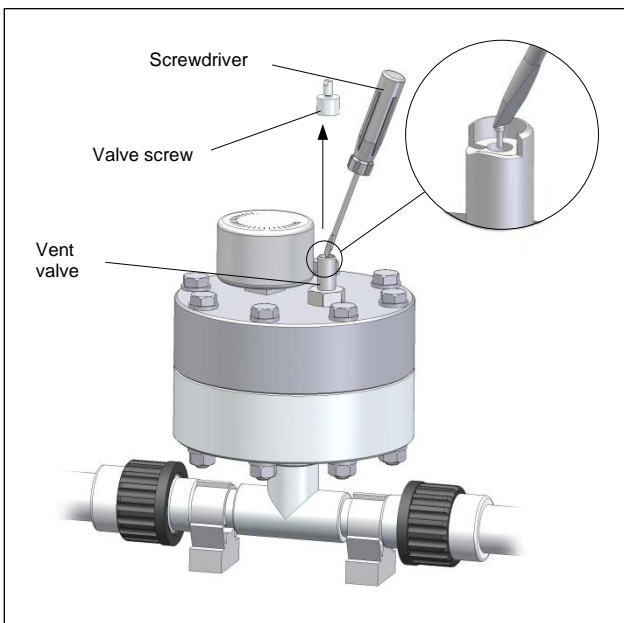

Fig. 13 „Bleeding air“

CAUTION !



The maximum allowable operating pressure depends on the maximum allowable pressure of the pulsation damper and the filling device. The smaller value is always decisive.

Proceed as follows:

- The complete system must be pressureless.
- Build up gas cushion inside the pulsation damper using the filling device described above by pressurizing the pulsation damper with a gas- / air pressure which corresponds to appr. 60% of the operating pressure to be expected (see Fig 12).
- Start-up pump / system; increase delivery rate of the pump slowly by adjusting the stroke frequency and / or the stroke length up to the maximum value (see Fig. 14).

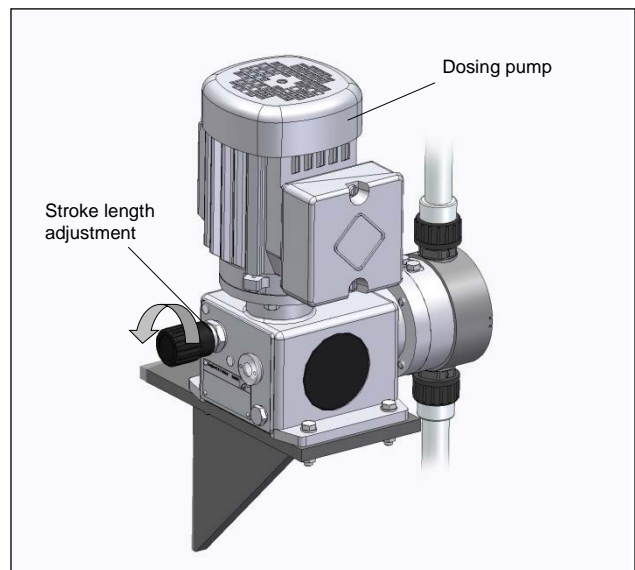

Fig. 14

- Check pressure gauge deflection. In case of a perfect operation a pointer deflection can always be observed with oscillating displacement pumps which may differ by ca. +/- 10% from the mean value (standard value) depending on the pulsation damper volume and the stroke volume of the pump.

Operating Instructions

- Carry out the following steps when this mean value is reached or exceeded:
Add air / gas carefully while the pump is operating. If the pointer deflection now reduces add air / gas until the pointer deflection has reached the minimum value and starts to increase slightly again. Then stop the air- / gas supply immediately. The pulsation damper is now set to the operating conditions (see Fig. 15).

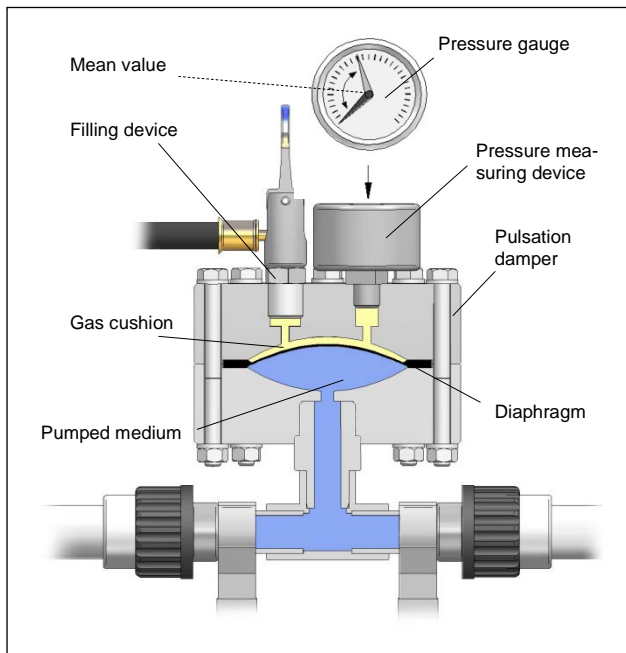

Fig. 15

If the pointer deflection increases immediately when air / gas is supplied, the air- / gas supply must be stopped. Bleed gas / air carefully until the pointer deflection has reached a minimum value and starts to increase slightly again. Stop bleeding air / gas. The pulsation damper is now set to the operating conditions (see Fig. 13).

CAUTION !



The pulsation damper may only be started when an air - / gas cushion builds up in the pulsation damper with a pressureless system (60% of the operating pressure to be expected).

CAUTION !



Use only gases that do not react chemically on the pumped medium or are inert.

13 Maintenance

To ensure perfect functioning, it is recommended to regularly check the gas precharge pressure and/or to control the pointer deflection every month.

Maintenance intervals:

- The gas precharge pressure must be checked and re-adjusted after each re-installation, or repairs. See Chapter 12 for the precise procedure.
- Generally, it is required to check the gas precharge pressure after each modification of the system parameters (filling of the gas - / air cushion according to Chapter 12).
- Check the filling device regularly for leaks.
- Regular checks:

Yearly visual check

Every 2 years – a pressure check using water with the 1.43-fold of the nominal pressure. For this purpose, disassemble the pulsation damper and test under pressure in a place which corresponds to the regulations for prevention of accidents.

CAUTION !



The operator is obliged to document these checks.

14 Spare- and wearing parts

Depending on their use and period of use, wearing parts must be replaced at regular intervals in order to ensure a safe function of the pulsation damper.

We recommend to replace the diaphragms after 3000 operating hours or at least once a year.

In case of a premature diaphragm rupture caused by hard operating conditions, switch off the pulsation damper and replace the diaphragm (see Chapter 15).

The following parts are considered as wearing parts of the pulsation damper:

- Diaphragm

The following parts are considered as spare parts of the pulsation damper:

- Screws
- Nuts
- Washers
- Pressure gauge
- Filling valve

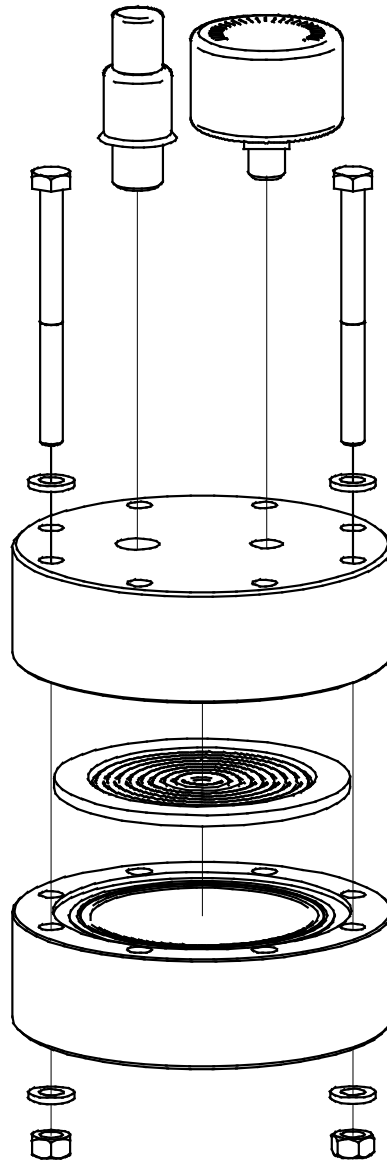

Fig. 16 Wearing parts

15 Changing the diaphragm

- Shut down the pulsation damper as described in Chapter 16.
- Loosen fastening screws crosswise and remove upper part of the housing (see Fig. 17).

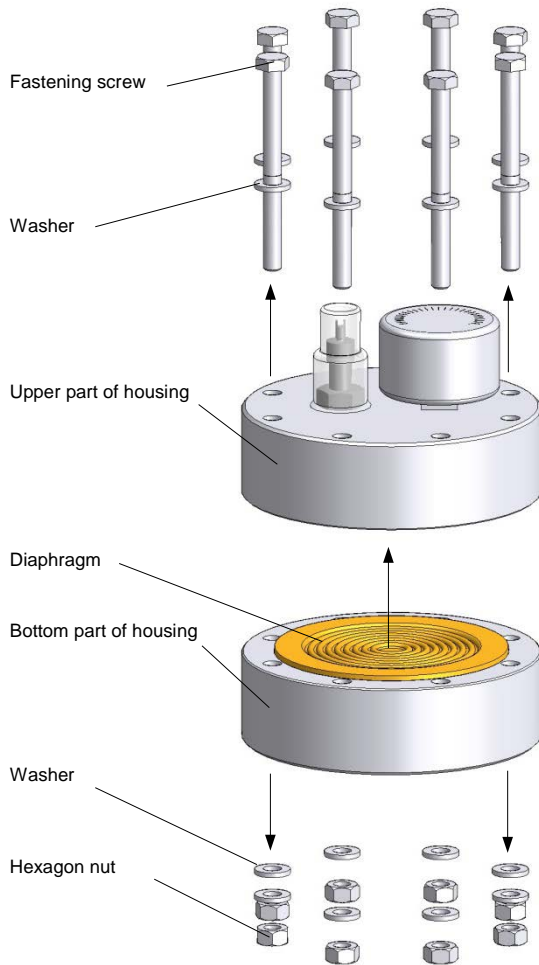

Fig. 17 Diaphragm replacement

- Remove the diaphragm (see Fig. 18).

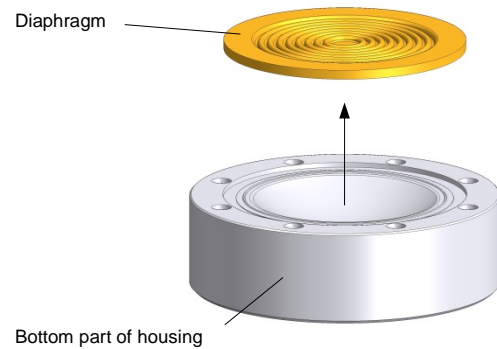

Fig. 18 Diaphragm replacement

CAUTION !



**Residues of the pumped medium may still be present!
Pay attention to the safety instructions (Chapter 3)!**

Assemble the pulsation damper in reversed order

- Insert new diaphragm with the curvature pointing downward (in case of PTFE diaphragms).

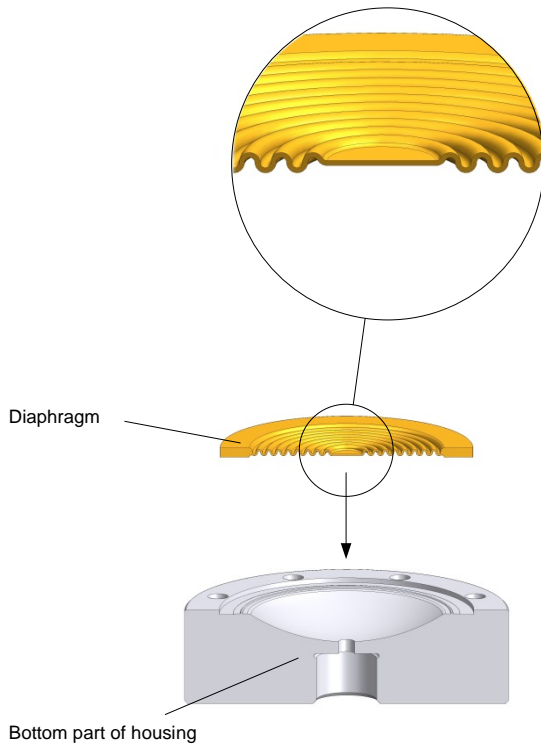

Fig. 19 Diaphragm replacement

- Place on upper part of housing and tighten fastening screws crosswise (tightening torques are specified in Chapter 15.1).
- Set the gas precharge pressure and start pulsation damper as described in Chapter 12.

15.1 Tightening torques for diaphragm pulsation dampers

Material	
PVC, PP, PVDF	
Type	Tightening torque [Nm]
720.1	7

Table 08 Tightening torques

16 Shut-down

- Shut-down the pump/system and secure it against restarting!
- Make sure that all pipes with pulsation dampers are pressureless!
- Drain the pulsation dampers and the connected pipes using drain cocks!
- Remove residues of the pumped medium from the pulsation damper by rinsing it with a compatible flushing agent!
- Reduce gas- / air pressure (gas cushion).
- The pulsation damper can then be removed from the pipe.

17 Disposal

Shut-down system. Please see "Shut-down".

17.1 Dismantling and transport

- Remove all fluid residues, clean thoroughly, neutralize and decontaminate.
- Package unit and ship.

17.2 Complete disposal

- Remove all fluid residues from unit.
- Drain off lubricants and dispose of according to regulations!
- Dismount materials and send them to a suitable waste disposal company!

CAUTION !



The consignee is responsible for damage caused by leaking fluids!

18 Clearance Certificate

NOTE!



Inspection / repair of machines and machine parts is only carried out after the opposite clearance certificate was filled in correctly and completely by authorized and qualified personnel.

NOTE!



Acceptance will be refused if parts are returned to the manufacturer without a proper clearance certificate.

All industrial companies are obligated by the legal provisions for occupational health, e.g. the workplaces ordinances, the Ordinance on Hazardous Substances, the regulations for prevention of accidents and the environmental protection regulations such as the Waste Management Act and the German Household Water Act to protect their employees or man and the environment from detrimental effects when handling hazardous substances.

Should special safety precautions be necessary despite careful draining and cleaning of the product the necessary information are to be provided.

Machines which are operated with radioactive media shall only be inspected and/or repaired in the safety area of the owner by a **sera** specialized fitter.

The clearance certificate is part of the inspection-/repair order. **sera** reserves the right to refuse acceptance of the order for other reasons.

NOTE!



Please make a copy and leave the original with the operating instructions!
(can also be downloaded from: www.sera-web.com)

Clearance Certificate

Product

Type Serial-No.

the product was carefully emptied before shipping / delivery, and cleaned inside and outside. YES

Conveying medium











Designation Concentration %

Properties

Please tick!

Harmless 

If either of the listed properties, then enclose the appropriate safety and handling instructions.

<input type="checkbox"/>  Toxic	<input type="checkbox"/>  Corrosive	<input type="checkbox"/>  Flammable	<input type="checkbox"/>  Oxidising	<input type="checkbox"/>  Unhealthy
<input type="checkbox"/>  Explosive	<input type="checkbox"/>  Dangerous for the environment	<input type="checkbox"/>  Irritant	<input type="checkbox"/>  Bio-hazardous	<input type="checkbox"/>  Radioactive

The product was used with health or water-polluting substances and came up with labeling requirements and pollution prone media in contact. YES NO

Special security arrangements with respect to health or water-hazardous media are in the further handling not required required

The following safety precautions regarding rinsing, residual liquids and waste disposal are required:

Process data

The product was used with the following operating conditions described conveying medium:

Temperature °C Pressure bar

Sender

Company: Telephone:

Contact person: FAX:

Address: E-mail:

Zip code, City: Your order No:

We confirm that we have the information in this safety certificate (Clearance Certificate) have been correctly and completely and that the returned parts were carefully cleaned.

The parts are sent free of residues of dangerous amount.

Place, Date

Department

Signature (and company stamp)

Notes

Notes

Notes

