

Pulsation dampers

Diaphragm-type pulsation dampers



sera - Pulsation dampers Diaphragm-type pulsation dampers

Advantages

- Avoid flow pulsation up to 95 % of oscillating positive displacement pumps
- Protect fittings and controlling devices – i. e. they increase their lifetimes
- Prevent oscillations and damages in the pipe system
- Improve the muffling of noises
- When mounted at suction side they avoid cavitation in the pump
- Improve the NPSH-value of the unit
- Allow the interconnection of pumps

Ask us to submit a quotation to meet your specific requirements!



Pulsation dampers

Diaphragm-type pulsation dampers



sera
Seybert & Rahier



Diaphragm-type pulsation damper type 713.1

sera-pulsation dampers correspond to test group I of the pressure vessel regulations and have been constructed according to the AD-sheets.

sera offers:

a) Diaphragm-type pulsation dampers.

The gas cushion is separated from the medium by an elastic diaphragm and is so protected from absorption.

b) Pulsation dampers without a separation between gas cushion and medium.

The gas is compressed to the damping volume after initiation. It is dissolved in the medium by and by so that it is necessary to check respectively supplement the gas cushion.

In order to achieve an optimum functioning pulsation dampers should be installed next to the dosing pump on suction and pressure side.

On the pressure side the pulsation damper smoothes all the pressure peaks created by the oscillating displacement pumps.

The acceleration on the suction side can be so strong that the liquid in the suction line cannot follow the suction stroke and the liquid column breaks off. In this case suction pulsation dampers ensure a continuous supply of the dosing head.



Pulsation damper type 802.1

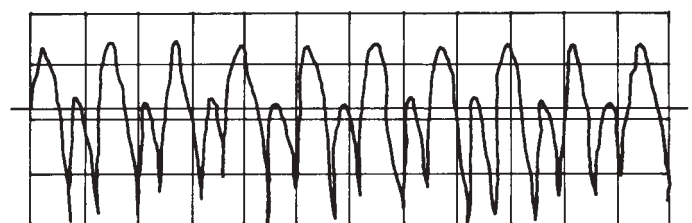

Without pulsation damper

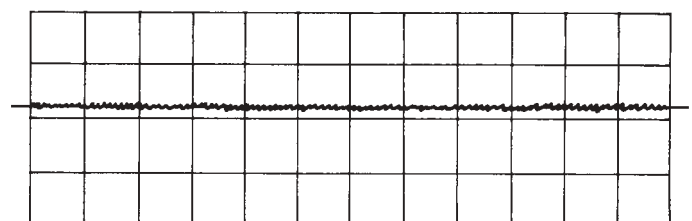

With pulsation damper

Pulsation dampers

Diaphragm-type pulsation dampers



sera
Seybert & Rahier

Diaphragm-type pulsation dampers made of galvanized steel, PVC, PP, PVDF and 1.4571

Type	Nominal volume V (l)	Max. operating pressure bar		Connection	
		Galvanized steel, PVC, PP, PVDF	1.4571	Flange DIN 2632 DN	Thread G
713.1	3	10	16	15	G 1
	3	10	16	20	G 1 1/4
	3	10	16	25	G 1 1/2
715.1	5	10	16	25	G 1 1/2
	5	10	16	32	G 2
	5	10	16	40	G 2 1/4

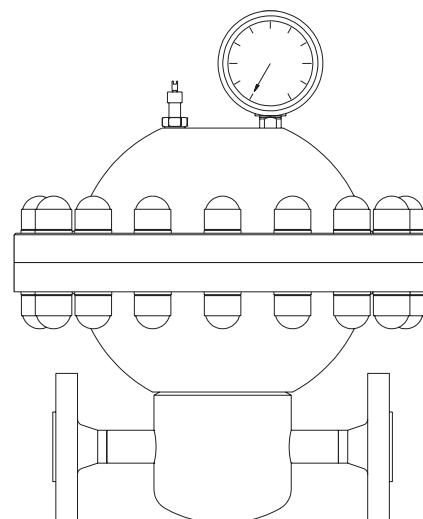

Materials

The high quality of the materials ensures continuous and reliable operation.

We have the optimum material for each requirement:

- Pulsation damper complete:
PVC, PP, PVDF
- Pulsation damper upper part:
Painted steel (with rubberized steel),
1.4305 (with 1.4571)
- Diaphragm:
EPDM, FPM

(Please ask us for any material required but not mentioned here.)

Pulsation dampers made of plastic

Type	Nominal volume V (l)	Max. operating pressure bar		Connection	
		PVC, PP		Flange acc. to DIN 2532 only PVC DN	Thread G
702.1	2	10		15	G 1
703.1	5	10		20	G 1 1/4
706.1	10	10		40	G 2 1/4

Materials: PVC and PP

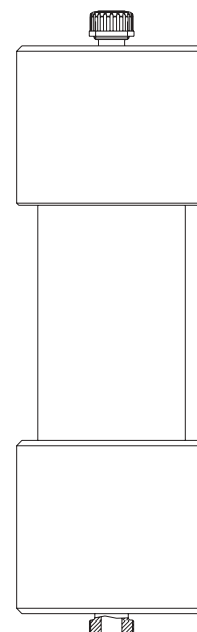

Pulsation dampers

Diaphragm-type pulsation dampers



sera
Seybert & Rahier

Pulsation dampers made of steel and 1.4571

Type	Nominal volume V (l)	Max. operating pressure bar	Connection	
			Flange DIN 2635, DIN 2633 DN	Thread G
802.1	2	25	15	G 1
803.1	10	16	20	G 1 1/4
804.1	10	16	25	-
805.1	10	16	32	-
806.1	10	16	40	-

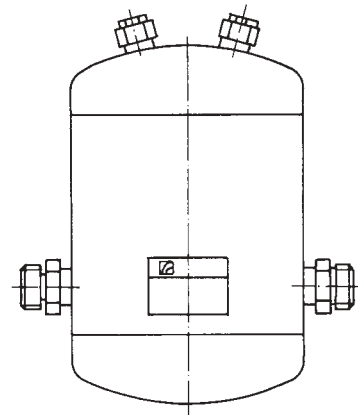

Pulsation dampers type 806.1 made of rubberized steel

Type	Nominal volume V (l)	Max. operating pressure bar	Connection DN	
806.1	10	16	40	

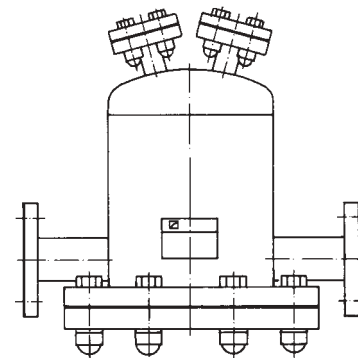

Other connections on request.

CE

sera
Dosing
Feeding
Compressing



Seybert & Rahier GmbH + Co. Betriebs-KG

sera-Straße 1 · D-34376 Immenhausen
Phone + 49 56 73 99 90
Fax + 49 56 73 99 91 55
e-mail: info@sera-info.de
Internet: www.sera-info.de