

Diaphragm-type pulsation damper with automatic diaphragm control



sera - Diaphragm-type pulsation damper

with automatic diaphragm control to be used in connection with sera - air driven diaphragm pumps.

They ensure a relatively smooth flow and eliminate pressure peaks which may lead to undesired vibrations in the pipe system.



Advantages

- pretension or manual adjustment not necessary
- adapts automatically to the operating conditions
- available with PTFE-diaphragm
- high quality housing materials
- maintenance-free
- silicone-free

Diaphragm-type pulsation damper with automatic diaphragm control

Design and function

The pulsation dampers consist of 2 housing parts in the main. A diaphragm is fixed between these parts. The diaphragm is connected with a tappet which opens or closes control borings in the air control valve depending on the operating conditions. It depends on the position of the diaphragm whether compressed air flows via the control boring to the reverse side of the diaphragm or air is drained off. The pulsation damper is installed in the by-pass for the air supply of the air-driven diaphragm pump and works automatically.

The stroke movement of the diaphragm/tappet can be visually controlled by means of the sight glass on the air control valve.

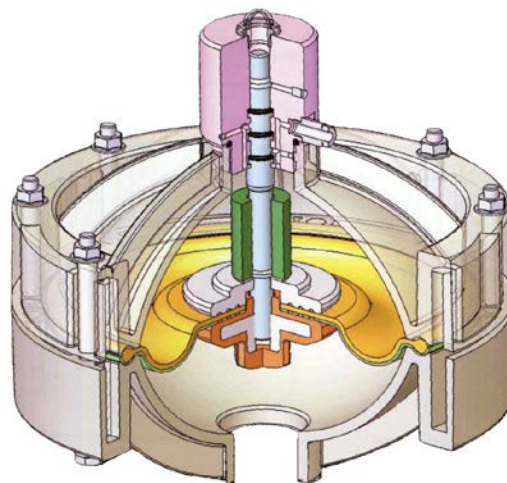

Materials

Several different materials are available for the medium-contacting components. The air-contacting housing part is always made of PP.

Materials available

Housing: PP, PP-CFK, ECTFE, ECTFE-CFK,
PPS – V, Aluminium

Diaphragms: Santoprene, NBR / PTFE
Hytrel / PTFE

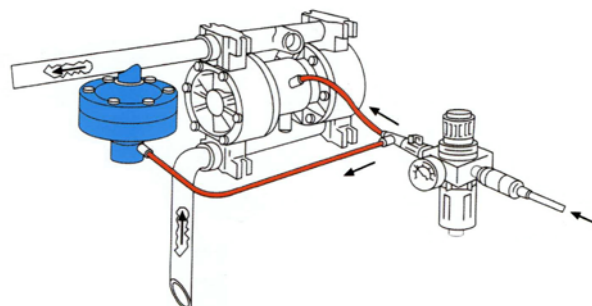

Pulsation damper type	Usable up to pump type	Max. throughput l/min.
MPD – 25.1	AP.. – 30	30
MPD – 150	AP.. – 150	150
MPD – 340	AP.. – 340	340
MPD – 650	AP.. – 650	650
MPD – 850	AP.. – 850	850

Local sera - Representative:

sera GmbH
sera-Straße 1
34376 Immenhausen
Germany
Tel. +49 5673 999-00
Fax +49 5673 999-01
www.sera-web.com
info@sera-web.com