

# Diaphragm-type relief valves Diaphragm-type pressure keeping valves

## sera Accessories

are important components for the correct and proper installation of dosing pumps, pipework systems and dosing units.



### Diaphragm-type relief valves

will protect pumps – fittings and pipework against excess pressure:

The valve opens when the set pressure is reached i.e. when the permissible pressure is exceeded.

### Diaphragm-type pressure keeping valves

prevent overdosing on an installation where siphoning can occur:

The set pressure produces the necessary positive differential pressure between the suction and delivery side of the pump.

Ask us to submit a quotation to meet your specific requirements!

# Diaphragm-type relief valves

## Diaphragm-type pressure keeping valves

sera valves are supplied ready for installation.  
The pressure settings correspond to the technical data as listed.  
The direction of flow is indicated with an arrow.

The valves are designed for horizontal installation.  
The mechanism housing or hood must be vertical. In this way the hydraulic damping of the diaphragm can be achieved – without vibration.

### Diaphragm-type relief valves

Especially for the protection of positive displacement pumps which can – in theory – build up an infinitely high pressure. When the delivery is closed or partially blocked pressures in excess of that permissible can be reached.

A closed shut-off valve - a build up crystals in the lines - clogged nozzles and filters can be the cause.

In such cases the smooth action of the sera relief valve is the optimum protection.

Type	Inlet/Outlet nominal size DN [DN]	Maximum pressure in bars [bar]	Pressure settings in bars [bar]	Valve body materials						Connections	
				+ = available		- = not available				with plastic	with metal
				PVC	PP	PVDF	1.4581	Cast iron 25	Cast iron hard rubber coated		
620.10	8	10	bis 10	+	+	+	+	-	-	G 3/4	G 3/4
622.10	15	10	bis 10	+	+	+	+	-	-	G 1	G 1
623.10	20	10	bis 10	+	+	+	+	+	+	G 1 1/4	Fl. DN 20
624.10	25	10	bis 10	+	+	+	+	+	+	G 1 1/2	Fl. DN 25
625.10	32	10	bis 10	+	+	+	+	+	+	G 2	Fl. DN 32
626.10	40	10	bis 10	+	+	+	+	+	+	G 2 1/4	Fl. DN 40
627.10	50	10	bis 10	+	+	+	+	+	+	G 2 1/2	Fl. DN 50

Diaphragm materials: PTFE-faced

Type 622.10 also available in PP-FRP and PVDF-FRP.

Types 623.10 – 627.10 in metallic execution: connections as fixed flanges PN10

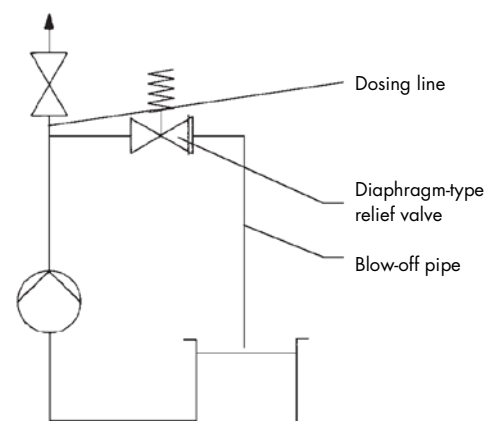
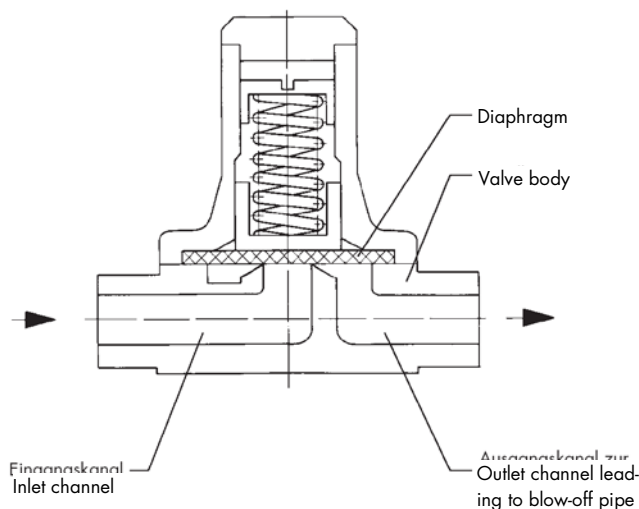

# Diaphragm-type relief valves

## Diaphragm-type pressure keeping valves

### Diaphragm-type relief valves for suspensions

There is a special construction for suspensions which are likely to clog the system.

The relief valve for suspensions is mounted directly into the pressure line where the continuous flow prevents clogging.

Type	Inlet/Outlet nominal size DN	Maximum pressure in bars	Pressure settings in bars	Valve body materials				Connections	
				+ = available		- = not available		with plastic	with metal internal thread
	[DN]	[bar]	[bar]	PVC	PP	PVDF	1.4581		
620.S	8	10	bis 2,5	+	+	+	+	G 5/8	G 1/4
622.S	15	10	bis 4,5	+	+	+	+	G 1	G 1/2
623.S	20	10	bis 5,5	+	+	+	+	G 1 1/4	G 3/4
624.S	25	10	bis 5,0	+	+	+	+	G 1 1/2	G 1
625.S	32	10	bis 10	+	+	+	+	G 2	G 1 1/4
626.S	40	10	bis 8,5	+	+	+	+	G 2 1/4	G 1 1/2
627.S	50	10	bis 10	+	+	+	+	G 2 1/2	G 2

Diaphragm materials: PTFE-faced

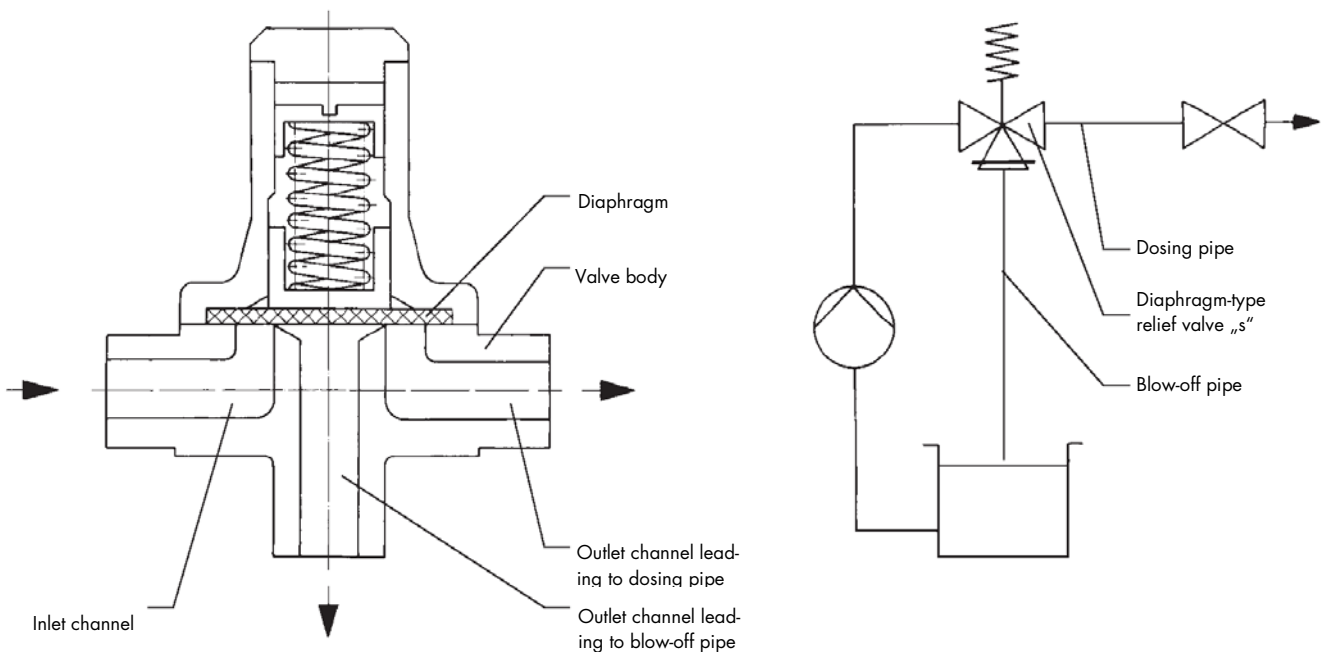

# Diaphragm-type relief valves

## Diaphragm-type pressure keeping valves

### Diaphragm-type pressure keeping valves

guarantee the required constant flow of a positive displacement pump if the suction pressure is higher than the delivery pressure.

This situation can be caused by an installation where the pump is allowed to siphon.

Type	Inlet/Outlet nominal size DN	Maximum pressure in bars	Pressure settings in bars	Valve body materials				Connections			
				+ = available		- = not available		with plastic		with metal	
	[DN]	[bar]	[bar]	PVC	PP	PVDF	1.4581	Cast iron 25	Cast iron hard rubber coated	G 3/4	G 3/4
620.D	8	10	bis 2,0	+	+	+	+	-	-	G 3/4	G 3/4
622.D	15	10	bis 2,0	+	+	+	+	-	-	G 1	G 1
623.D	20	10	bis 3,5	+	+	+	+	+	+	G 1 1/4	Fl. DN 20
624.D	25	10	bis 3,0	+	+	+	+	+	+	G 1 1/2	Fl. DN 25
625.D	32	10	bis 7,0	+	+	+	+	+	+	G 2	Fl. DN 32
626.D	40	10	bis 7,0	+	+	+	+	+	+	G 2 1/4	Fl. DN 40
627.D	50	10	bis 7,0	+	+	+	+	+	+	G 2 1/2	Fl. DN 50

Diaphragm materials: PTFE-faced

Type 622.D also available in PP-FRP and PVDF-FRP.

Type 623.D – 627.D in metallic execution: connections as fixed flanges PN10

Please ask us for any material required but not mentioned here.

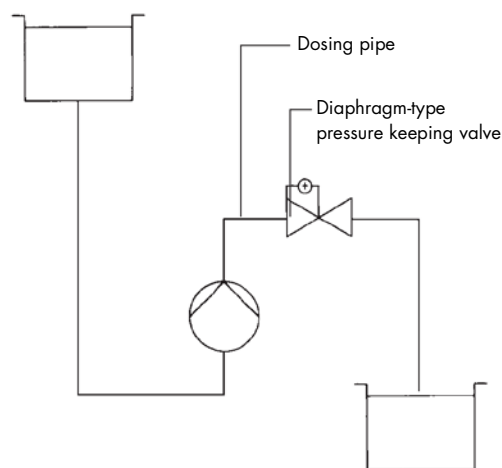
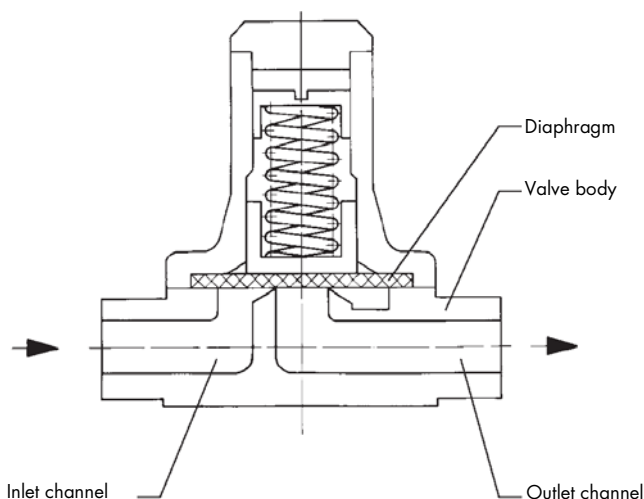

Local sera - Representative:

sera GmbH  
 sera-Straße 1  
 34376 Immenhausen  
 Germany  
 Tel. +49 5673 999-00  
 Fax +49 5673 999-01  
 www.sera-web.com  
 info@sera-web.com