

Operating Instructions

Product: Diaphragm relief valve

Type: 620.10
622.10
623.10
624.10
625.10
626.10
627.10

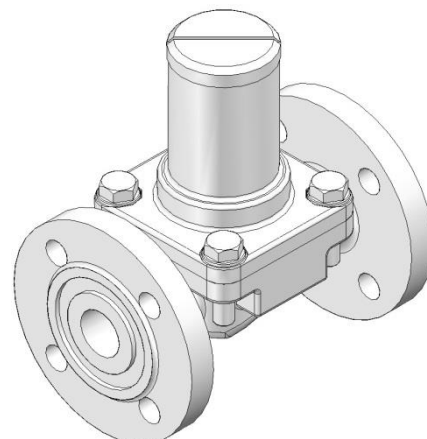
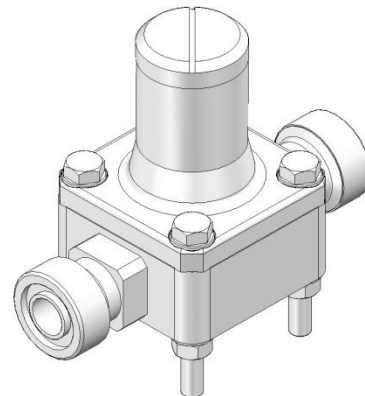
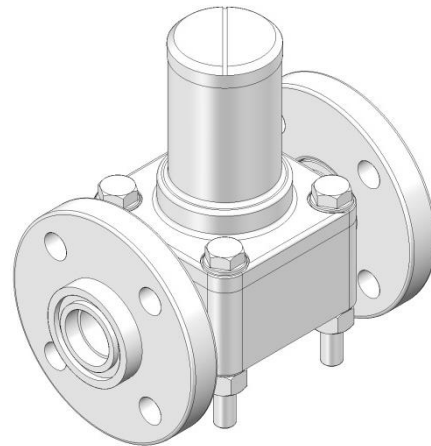
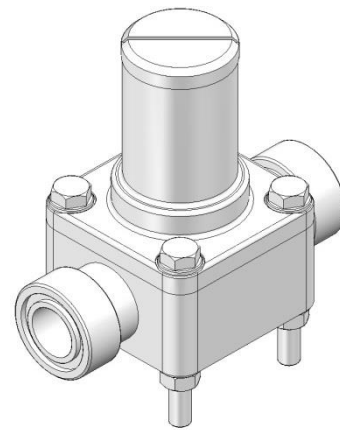

Please state here the exact type and serial number of your diaphragm relief valve.
(can be read off the type plate on the diaphragm relief valve)

Type:

Serial No.:

These data are important in case of queries or for ordering spare- and wearing parts and must absolutely be stated.

Manufacturer:

sera GmbH
sera-Straße 1
34376 Immenhausen
Germany
Tel.: +49 5673 999-00
Fax.: +49 5673 999-01
www.sera-web.com
info@sera-web.com

Translation of the original operating instructions!

Table of contents

1	General.....	3	14	Changing the diaphragm	15
2	Types.....	3	14.1	General	15
2.1	Type plate.....	3	14.2	Changing the diaphragm	15
2.2	Materials	4	15	Shut-down	16
3	Safety instructions	4	16	Disposal	16
3.1	Quality instructions / purpose	4	16.1	Dismantling and transport.....	16
3.2	Marking of notes	4	16.2	Complete disposal.....	16
3.2.1	Marking of notes in these operating instructions.....	4	17	Clearance Certificate.....	17
3.2.2	Marking of notes on the product.....	4			
3.3	Dangers in case of inobservance of the safety instructions	4			
3.4	Safety conscious working.....	4			
3.5	Intended use.....	5			
3.6	Approved installation-, maintenance and operating personnel	5			
3.7	Personal protection for maintenance and service....	5			
4	Areas of application and function	6			
5	Test / identification.....	6			
6	Checking the packaging at the place of destination	6			
7	Storage.....	6			
8	Technical specifications	7			
8.1	Dimensions of the diaphragm relief valve.....	7			
8.1.1	PP-, PVC-, PVDF-, PP-GFK-, PVDF-GFK-design	7			
8.1.2	1.4581-design.....	8			
8.1.3	GG-, GG-rubber-coated, 1.4581-design	9			
8.2	Technical specifications	10			
9	Installation	10			
9.1	Supply line.....	11			
9.2	Return line	11			
10	Start-up.....	11			
11	Adjustment.....	12			
12	Operation in explosion-hazardous areas.....	12			
13	Spare- and wearing parts.....	12			
13.1	Spare- and wearing parts kit	13			

Operating Instructions

1 General

Before commissioning and during operation of the **sera** diaphragm relief valve the respective regulations valid at the place of installation are to be observed.

sera diaphragm relief valves are delivered ready for assembly.

Carefully read these instructions and especially the safety instructions herein contained before installation and initial start-up of the valves.

The **sera** diaphragm relief valve protects the pump, fittings, and pipes from unacceptable overpressure.

2 Types

2.1 Type plate

Each **sera** diaphragm relief valve is factory provided with a type plate. The following information can be found on this type plate.

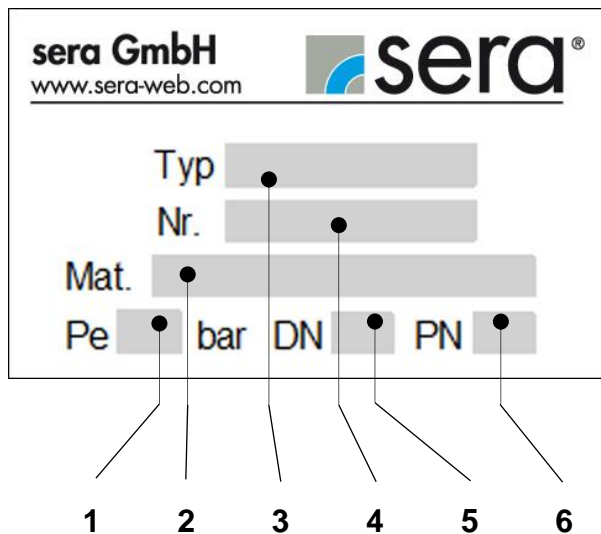

Fig. 01 Type plate

Explanation of the indications on the type plate		
1	Pe	Set pressure: The set pressure corresponds to the overpressure (at the valve inlet) at which the valve opens under test conditions (atmospheric pressure at the valve outlet).
2	Mat.	Materials: Material specifications for housing / diaphragm according to DIN/ISO
3	Type	Diaphragm relief valve type
4	No.	Serial number of the diaphragm relief valve
5	DN	Nominal width: The nominal width is a characteristic parameter which is used for pipes and parts, e.g. tubes, tube connections, fittings etc. matching each other. Nominal widths correspond to the pipe diameter in mm.
6	PN	Nominal pressure: The nominal pressure is the permissible operating pressure in bar at 20° C.

Table 01 Explanation of type plate

Operating Instructions

2.2 Materials

The materials used are stated in the order confirmation.

3 Safety instructions

3.1 Quality instructions / purpose

Please read these operating instructions carefully before the diaphragm relief valve is started or serviced. Observance of these operating instructions and, in particular, the safety instructions, helps to

- avoid dangers to persons, machines, and environment
- increase reliability and service life of the diaphragm relief valve and the complete system
- reduce repair cost and downtime.

The **sera** quality management and quality assurance system for pumps, systems, and fittings is certified according to ISO 9001:2008.

sera products comply with the valid safety requirements and accident prevention regulations.

CAUTION !



Always keep these operating instructions within reach at the place of installation.

CAUTION !



Pay attention to the safety data sheet of the pumped medium! The owner must take corresponding accident prevention measures to protect operating personnel from danger through the pumped media used!

3.2 Marking of notes

3.2.1 Marking of notes in these operating instructions

Special notes in these operating instructions are marked with the general danger symbol



(safety symbol in compliance with DIN 4844 – W9)

3.2.2 Marking of notes on the product

Symbols which are directly attached to the diaphragm relief valve, e.g. symbols for flow direction, are to be observed and kept in legible condition.

3.3 Dangers in case of inobservance of the safety instructions

Inobservance of these safety instructions can result in danger to persons, hazards to the environment and damage to the diaphragm relief valve.

Inobservance can result in:

- Failure of important functions of the diaphragm relief valve/system
- Inobservance of prescribed methods for maintenance and servicing
- Danger to persons through chemical influences
- Hazards to the environment through leaking dangerous media

3.4 Safety conscious working

The safety instructions specified in these operating instructions, the national regulations concerning accident prevention as well as internal working-, operating-, and safety instructions of the owner are to be observed.

Operating Instructions

3.5 Intended use

sera diaphragm relief valves are only to be deployed according to the intended purpose stated in the order confirmation.

sera does not assume any responsibility for damage resulting from an operation which does not conform with the intended use.

If the diaphragm relief valve is to be used for other applications, then the suitability of the valve for the new operating conditions must be discussed with **sera** beforehand!

Criteria for proper operation of the diaphragm relief valve:

- Max. operating pressure of the diaphragm relief valve
- Observe characteristics of the pumped medium (please see safety- and product data sheet of the pumped medium – the safety data sheet is to be provided by the supplier of the chemical)
- Resistance of the materials which come in contact with the pumped medium
- Operating conditions at the place of installation
- Temperature of the pumped medium

sera does not assume any responsibility if these criteria are not or only partly observed by the owner / operator.

CAUTION !



The structural design of the diaphragm relief valve must not be changed!

3.6 Approved installation-, maintenance and operating personnel

The system operator may only approve persons to operate or maintain the unit, who are at least eighteen years old and suitably qualified, and of a physical and mental state to perform the tasks entrusted to them. These persons must be properly instructed and act responsibly, properly and reliably. The operating personnel must be familiar with all applicable accident prevention and safety instructions and regulations.

3.7 Personal protection for maintenance and service

In order to avoid risks to health, the provisions of the German Ordinance on Hazardous Substances (GefStoffV) (§14 Safety Data Sheet) and relevant national safety regulations for the pumped medium and the operating conditions of the diaphragm relief valves must strictly be adhered to.

CAUTION !



Wear protective clothing, gloves, and a face protecting mask.

CAUTION !



Personal protective equipment must be provided by the owner!

4 Areas of application and function

sera diaphragm relief valves can be used for liquid media without solid matters but exclusively for the intended use as specified by the manufacturer.

sera diaphragm relief valves protect especially oscillating displacement pumps which, in theory, can build up a infinitely high pressure. If pressure lines are restricted or closed the pressure may reach a multiple of the permissible system pressure, e.g. owing to clogged lines (foreign matters, crystals) or closed shut-off valves, clogged nozzles or filters etc.

CAUTION !



As sera diaphragm relief valves cannot reduce acceleration pressure peaks with oscillating displacement pumps an additional pulsation damper is to be provided.

CAUTION !



sera diaphragm relief valves are no safety valves as per the requirements of the regulations for pressure systems 2014/68/EU.

CAUTION !



Do not change the setting of the relief valve!

5 Test / identification

sera diaphragm relief valves are tested in our works and set to an operative pressure.

The set pressure corresponds to the technical delivery conditions which are indicated on the type plate (see Fig. 01/02/Table 01).

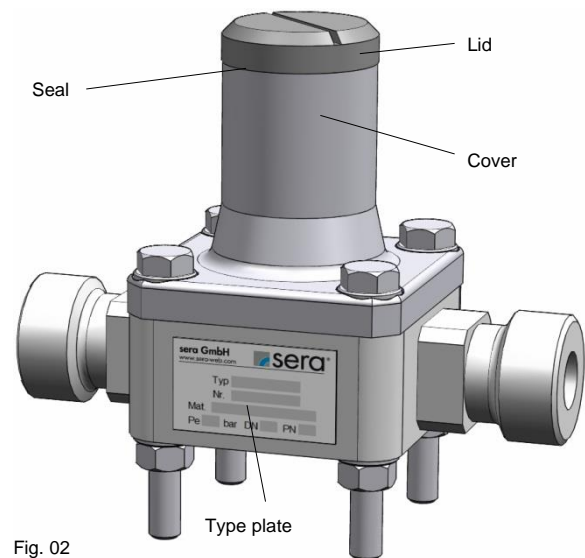

Fig. 02

6 Checking the packaging at the place of destination

On delivery, immediately check the packaging for damage. Report any external damage immediately to the transport company, and fill out a damage report. After the transport company has recorded the damage, open the package and check the contents for damage.

7 Storage

An undamaged packaging protects the unit during subsequent storage and should only be opened when the diaphragm relief valve is installed.

Proper storage increases the service life of the diaphragm relief valve and comprises prevention of negative influences such as heat, humidity, dust, chemicals etc.

The following storage instructions are to be observed:

- Storage place: cool, dry, dust-free and slightly ventilated
- Storage temperatures between -10°C and +45°C
- Relative air humidity not more than 50%.

If these values are exceeded, metal products should be sealed in foil and protected from condensation water with a suitable desiccant.

Do not store solvents, fuels, lubricants, chemicals, acids, disinfectants and similar in the storage room.

8 Technical specifications

8.1 Dimensions of the diaphragm relief valve

8.1.1 PP-, PVC-, PVDF-, PP-GFK-, PVDF-GFK-design

Connection: Thread pipe connection

Connection: Loose flange

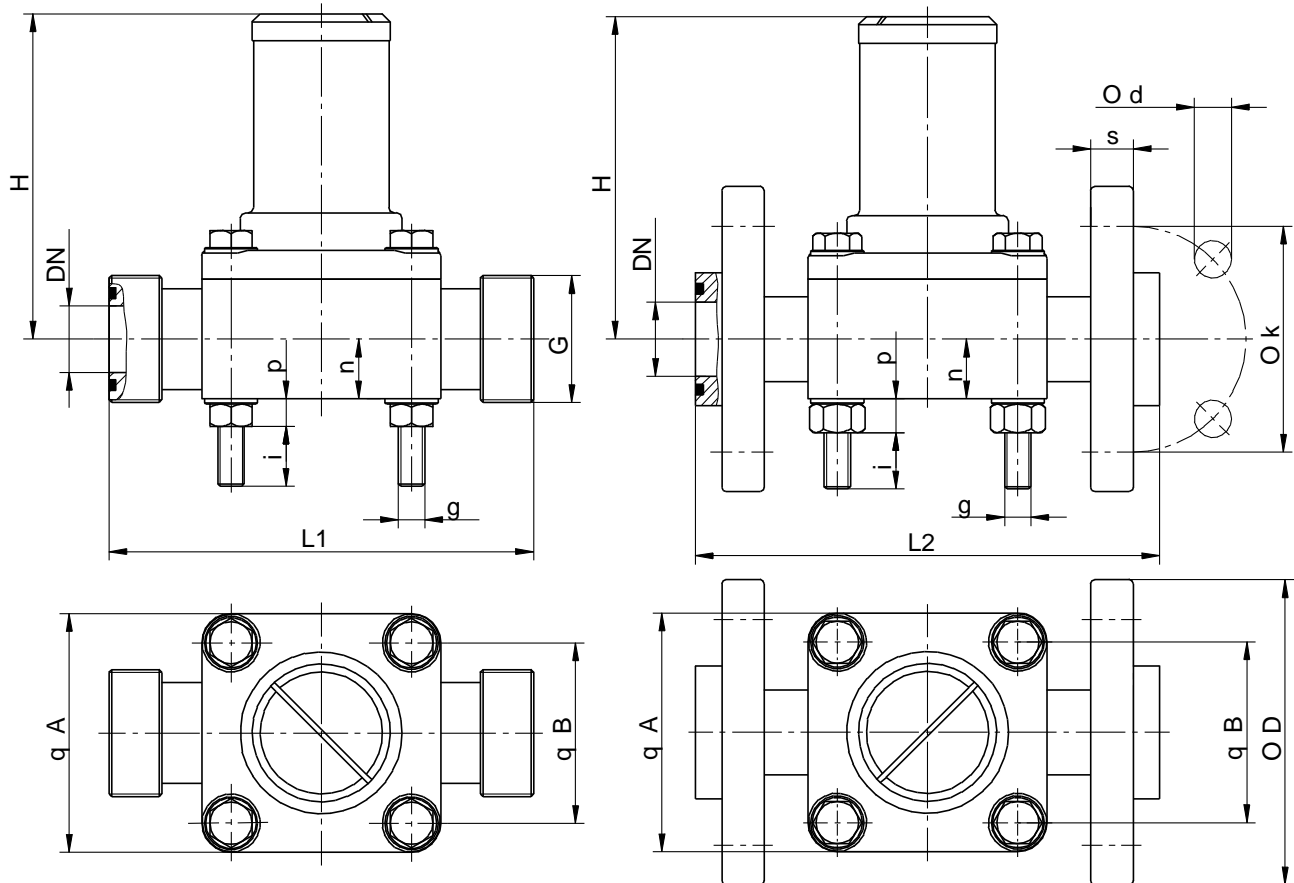

Fig. 03 Dimensions

Type	DN	G	A	B	H	L1	n	g ¹⁾	i ¹⁾	p ¹⁾	L2	D	k	s		d
														PP	PVC	
620.10	8	G ¾	50	38	80	80	13	M5	15	5	110	90	60	12	10	14
622.10	15	G 1	72	54	90	115	15	M8	17	8	145	95	65	12	11	14
623.10	20	G 1 ¼	80	60	116	130	28	M8	17	8	160	105	75	12	12	14
624.10	25	G 1 ½	90	68	123	160	22,5	M10	11	10	175	115	85	16	14	14
625.10	32	G 2	100	76	157	180	24	M10	15	10	200	140	100	16	15	18
626.10	40	G 2 ¼	115	87	180	235	30	M12	26	13	235	150	110	20	16	18
627.10	50	G 2 ¾	140	106	185	260	38	M12	18	13	260	165	125	20	18	18

Table 02 Dimensions

¹⁾ Fixture for mounting the valve on brackets etc.

8.1.2 1.4581-design

Connection: Thread pipe connection

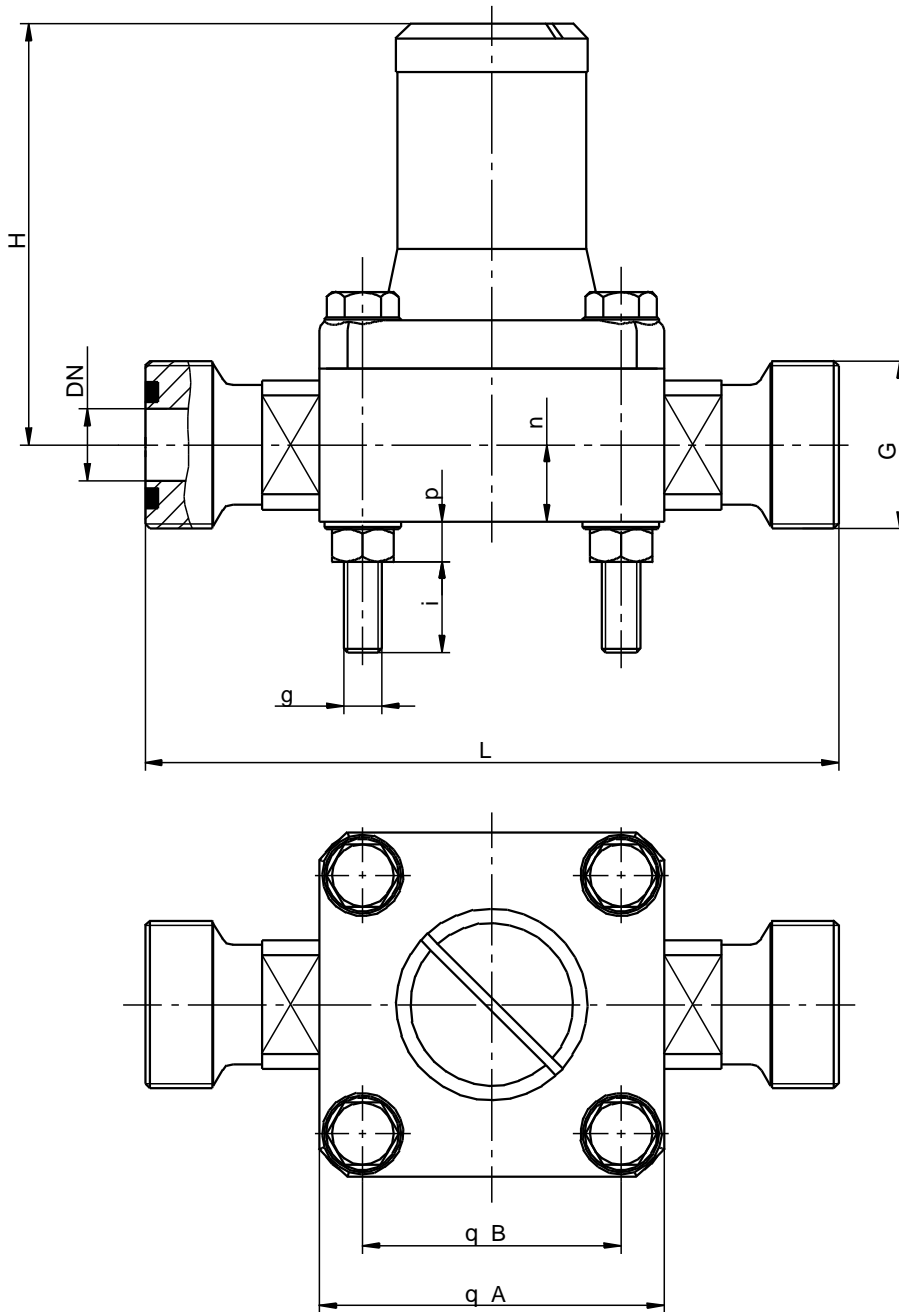

Fig. 04 Dimensions

Type	DN	G	A	B	H	L	n	g ¹⁾	i ¹⁾	p ¹⁾
620.10	8	G 3/4	50	38	80	110	13	M5	10	5
622.10	15	G 1	72	54	88	145	16	M8	17	8

Table 03 Dimensions

¹⁾ Fixture for mounting the valve on brackets etc.

8.1.3 GG-, GG-rubber-coated, 1.4581-design

Connecting dimensions according to DIN 2501, PN 10 / ANSI 150 lbs/sq in

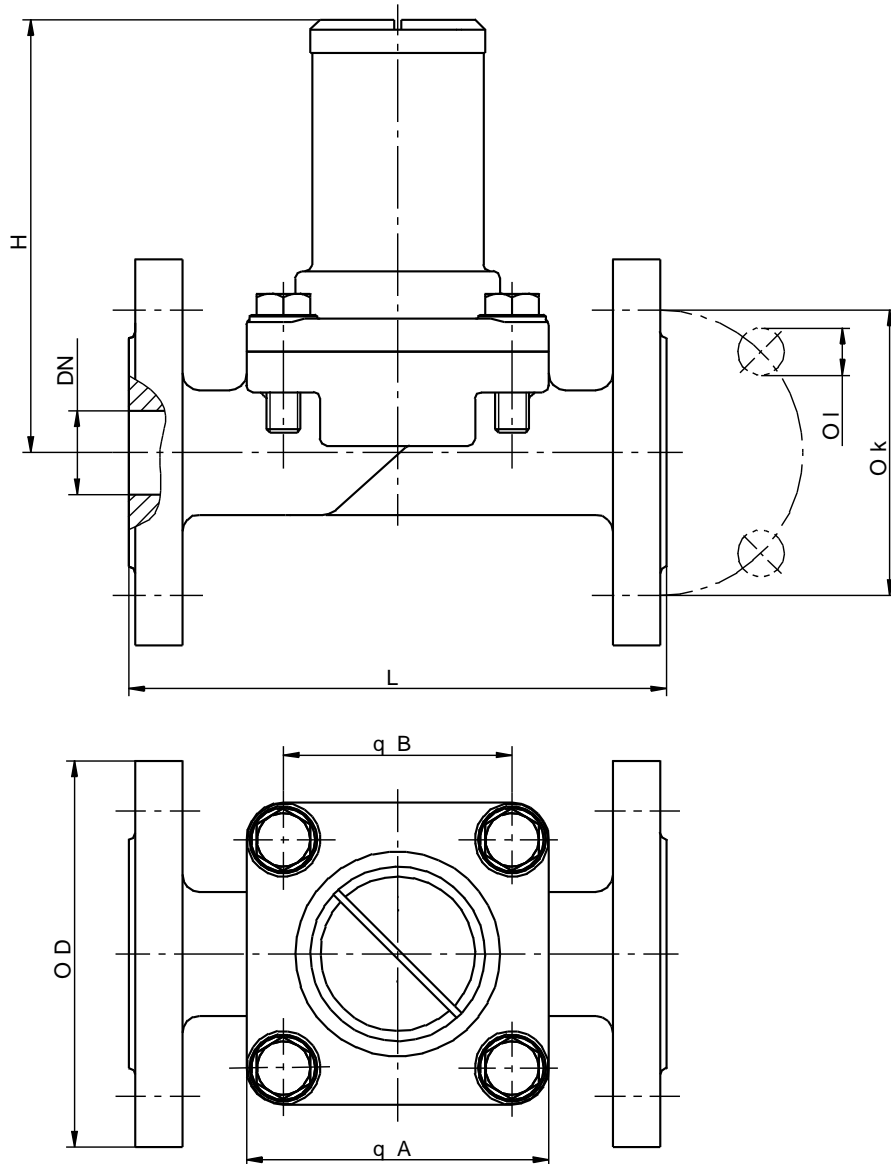

Fig. 05 Dimensions

Type	DN	A	B	H	L	D ¹⁾	D ²⁾	k ¹⁾	k ²⁾	I ¹⁾	I ²⁾
623.10	20	80	60	125	150	105	99	75	70	14	16
624.10	25	90	68	130	160	115	108	85	79	14	16
625.10	32	100	76	165	180	140	118	100	89	18	16
626.10	40	115	87	180	200	150	127	110	98	18	16
627.10	50	140	106	185	230	165	153	125	121	18	19

Table 04 Dimensions

¹⁾ Connecting dimensions according to DIN 2501

²⁾ Connecting dimensions ANSI150

8.2 Technical specifications

Type	Max. allowable operating pressure	Set pressure p_e	Max. capacity Q	K_{vs} value
	[bar]	[bar]	l/h	m^3/h
620.10	10	2,5 ... 10	200	0,26
622.10	10	2,5 ... 10	500	0,6
623.10	10	1,5 ... 10	1000	1,12
624.10	10	1,5 ... 10	2000	2,1
625.10	10	1,5 ... 10	4000	4,0
626.10	10	1,5 ... 10	7000	6,7
627.10	10	1,5 ... 10	10000	9,12

Table 05 Technical data

9 Installation

- The cover is to be mounted vertically to the top.
- The diaphragm relief valve is to be installed in such a way that no static, dynamic or thermal loads from the supply- or return line are transmitted to the relief valve.
- Install the diaphragm relief valve near the pump and in front of the first shut-off valve.

- The flow direction is indicated by an arrow.

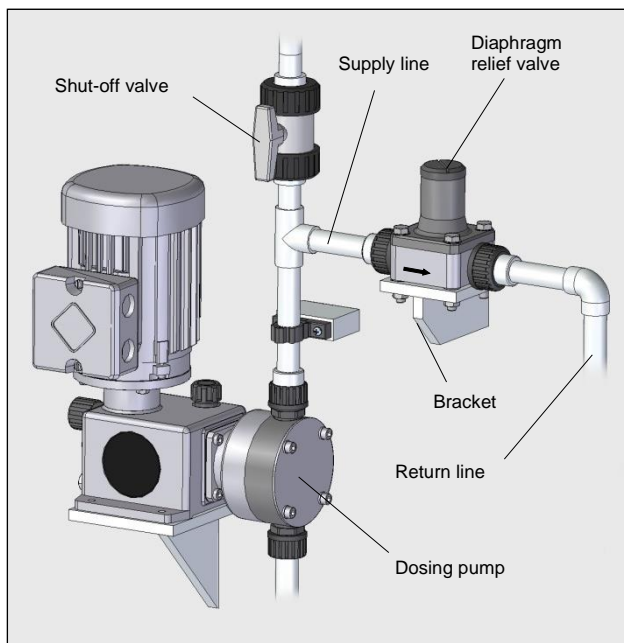

Fig. 06 Example of an installation

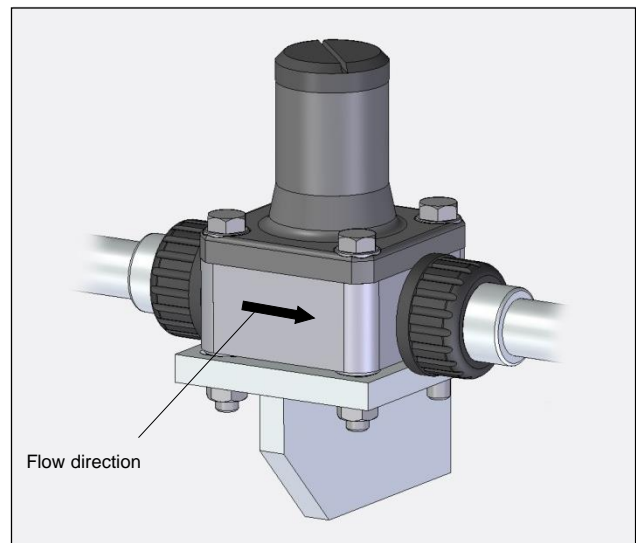

Fig. 07

Operating Instructions

9.1 Supply line

Keep the supply line as short as possible and lay it in such a way that only low acceleration pressures or pressure losses develop.

Avoid contamination and precipitations.

9.2 Return line

Keep the return line as short as possible and lay it downgrade. Elbows are to be preferred to angles. The return line must not be under pressure, provide for a free outlet (see Fig. 06). Make sure that there are no shut-off valves or check valves in the return line.

If the return line is linked to the suction line of the pump, no check valves may be installed in the suction line.

Lay the lines in such a way that precipitations are excluded.

10 Start-up

During commissioning, observe the following:

- Open all shut-off valves that are mounted in the suction line and pressure line (except for flushing and discharge fittings).
- Start pump / system.
- Slowly increase the delivery rate via the stroke frequency or stroke length adjustment to the maximum setting (see Fig. 08).

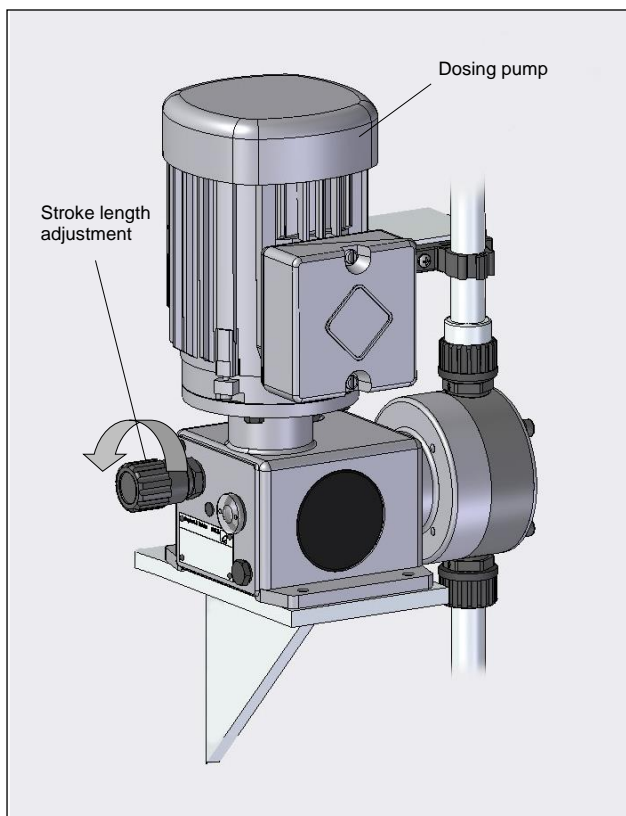

Fig. 08

The diaphragm closes the inlet channel by the pressure spring initial tension (= set pressure of the valve in bar).

If the medium at the diaphragm reaches the set pressure, the diaphragm is lifted and the medium flows in the outlet channel (see Fig. 09).

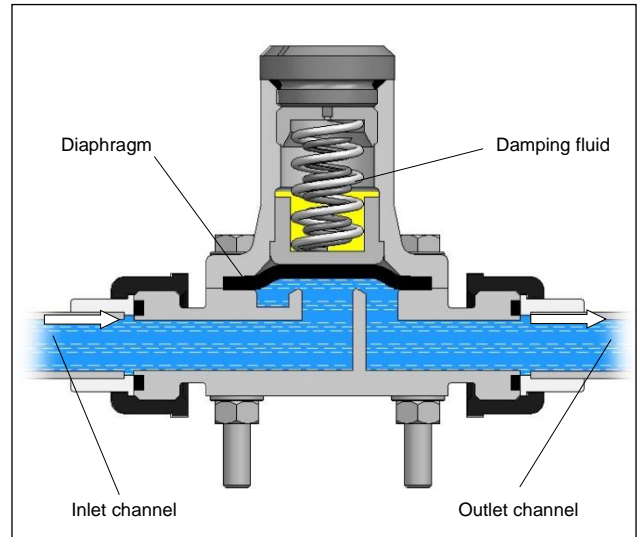

Fig. 09 Operational mode

The diaphragm closes the inlet channel only when the pressure of the medium drops below the set pressure (see Fig. 10).

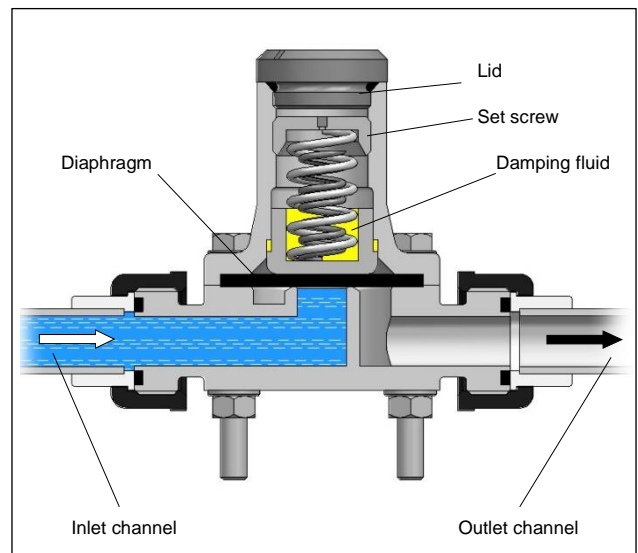

Fig. 10 Operational mode

CAUTION!



The use of damping fluid is shown of the table 07 (page 16).

Operating Instructions

11 Adjustment

Check the set pressure by means of e.g. a pipe test pump. If the set pressure does not match the indication on the type plate, remove lid and correct pressure using the set screw.

- Turning counterclockwise: the set pressure reduces
- Turning clockwise: the set pressure increases

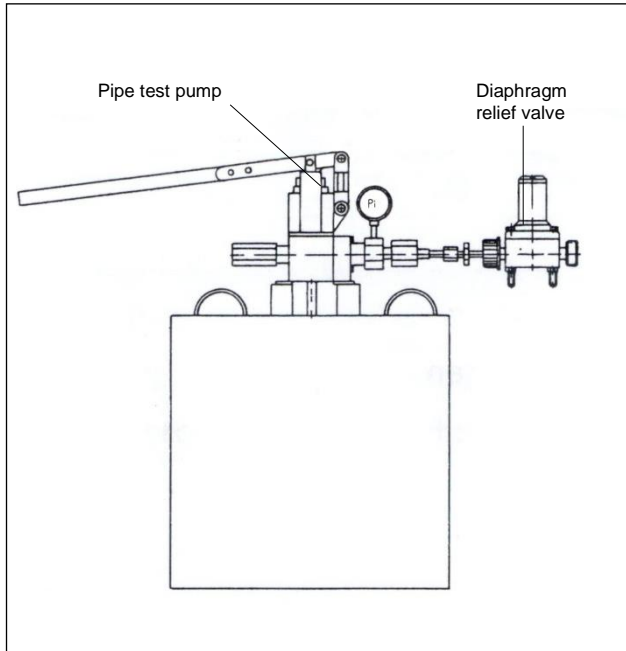

Fig.11 Check

CAUTION !



The operator is obliged to document these checks.

CAUTION !



Never screw in the set screw to a depth so that the spring(s) is (are) compressed to solid length!

CAUTION !



sera – diaphragm relief valves are factory-set to the set pressure stated in the order confirmation. A sealing wax seal is located on the transition piece between lid and cover.

12 Operation in explosion-hazardous areas

As there are no ignition sources the relief valves can be used unproblematically in the hazardous area (ATEX) acc. to 2014/34/EU.

The relief valves have to be integrated into the equipotential bonding by customer.

13 Spare- and wearing parts

Depending on their use and period of use, wearing parts must be replaced at regular intervals in order to ensure a safe function of the diaphragm relief valve.

The diaphragm should be replaced:
Every 3000 hours, at least once a year.

In case of a premature diaphragm rupture caused by hard operating conditions, switch off the diaphragm relief valve and replace the diaphragm (see Chapter 13).

13.1 Spare- and wearing parts kit

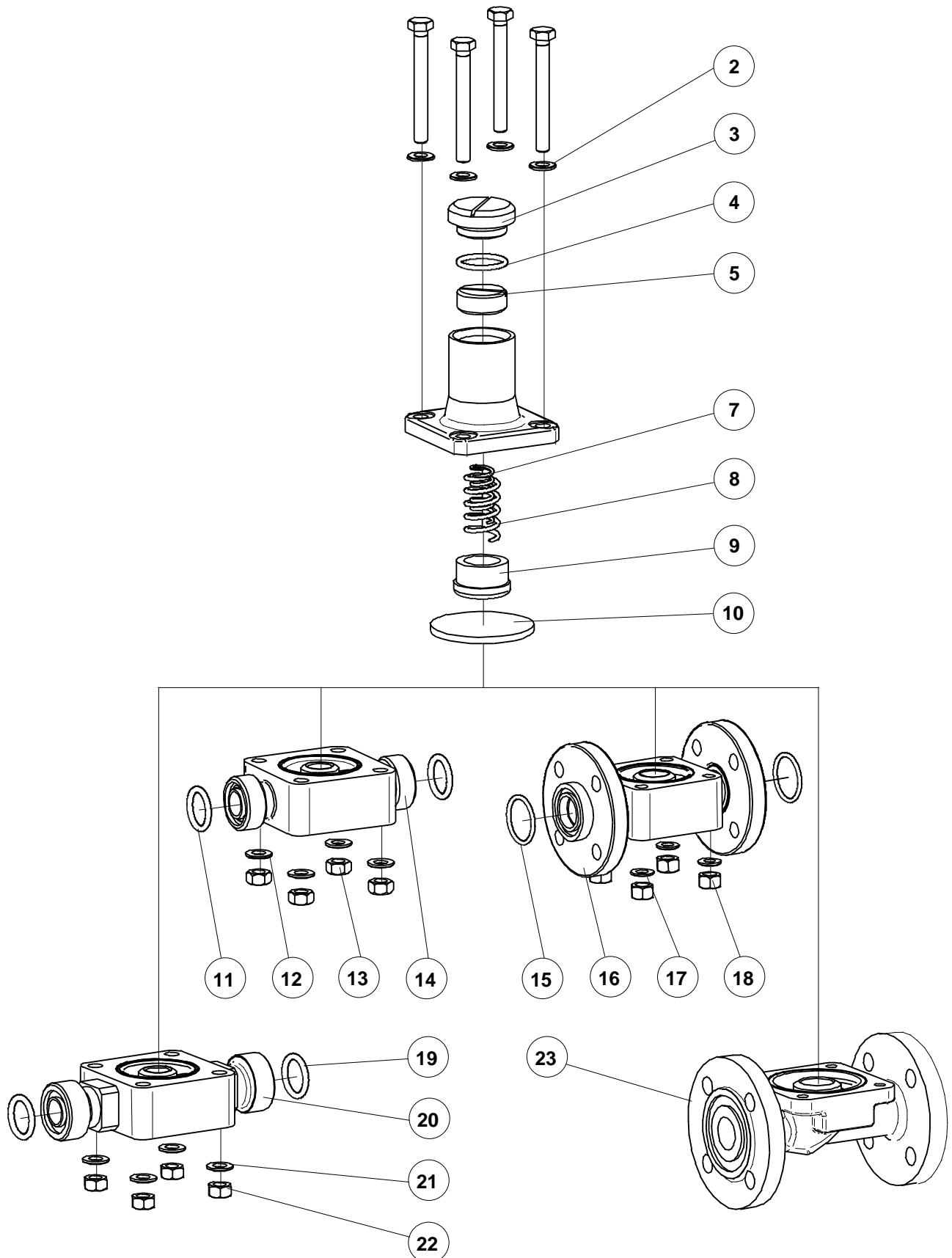

Fig. 12 Spare- and wearing parts kit

Operating Instructions

Spare- and wearing parts kit

Valve body kit (plastic, connection: thread pipe connection)	
Item	Designation
1	Hexagon screws
2	Disks
3	Lid
4	O-ring
6	Cover
11	O-rings
12	Disks
13	Nuts
14	Valve body

Valve body kit (plastic, connection: loose flange)	
Item	Designation
1	Hexagon screws
2	Disks
3	Lid
4	O-ring
6	Cover
15	O-rings
16	Valve body
17	Disks
18	Nuts

Valve body kit (1.4581)	
Item	Designation
1	Hexagon screws
2	Disks
3	Lid
4	O-ring
6	Cover
19	O-rings
20	Valve body
21	Disks
22	Nuts

Valve body kit (GG, GG-rubber-coated, 1.4581)	
Item	Designation
1	Hexagon screws
2	Disks
3	Lid
4	O-ring
6	Cover
23	Valve body

Diaphragm kit	
Item	Designation
5	Set screw
7	Pressure spring
8	Pressure spring
9	Pressure disk
10	Diaphragm
10.1	Damping fluid

CAUTION !



The use of damping fluid is shown of the table 07 (page 16).

14 Changing the diaphragm

14.1 General

In case of maintenance- and repair work on the diaphragm relief valve the safety- and warning notes in Chapter 3 are to be observed.

Pay attention to all instructions concerning the handling of the pumped medium when the diaphragm relief valve is opened. Observe the EC safety data sheets!

- Unscrew the set screw
- Remove pressure spring(s)
- Unscrew screws
- Remove cover on the valve body
- Diaphragm is now freely accessible and can be replaced

CAUTION ! 

The diaphragm may only be replaced by authorized and qualified personnel.

14.2 Changing the diaphragm

- Unscrew the lid
- Measure dimension "T" of the set screw with a caliper gauge and document in Table 06.

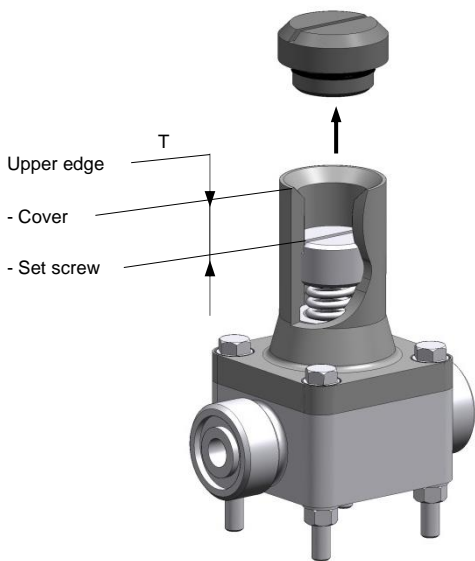

Fig. 13 Setting

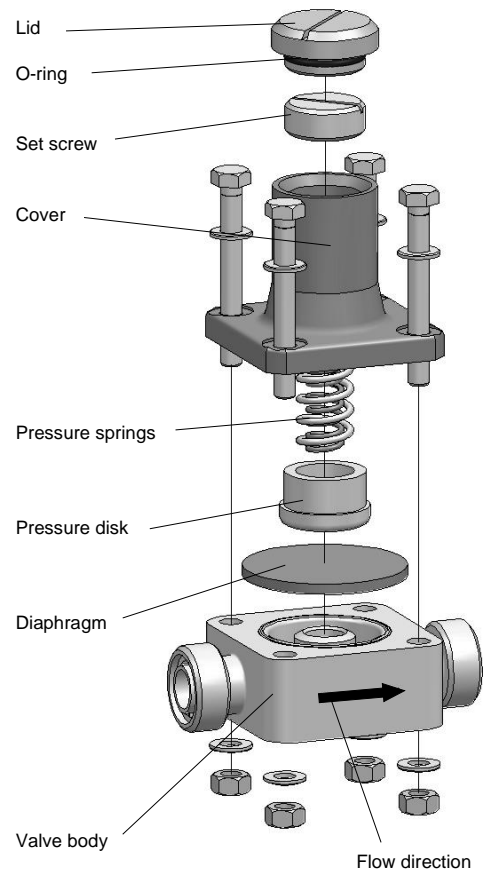

Fig. 14 Diaphragm replacement

Type	Dimension "T" (mm)
620.10	
622.10	
623.10	
624.10	
625.10	
626.10	
627.10	

Table 06

Assemble the pump in reversed order

- Insert diaphragm (PTFE-foil pointing downstream) in the recess of the cover.
- Fasten cover with screws on the valve housing.
- Fill in damping fluid (for type and quantity please see Table 07).

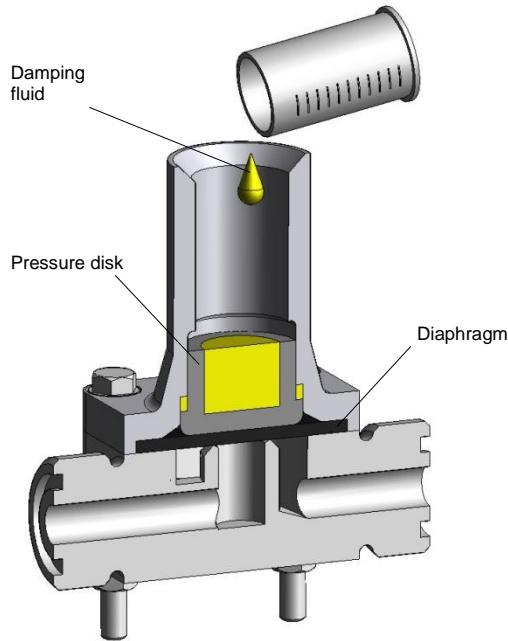

Fig. 15

Type	Damping fluid	Quantity
		[ml]
620.10	Glycerine DAB 87	excluding
622.10		excluding
623.10		excluding
624.10		excluding
625.10		36
626.10		56
627.10		138

Table 07 Damping fluid

- Insert pressure spring.
- Screw in set screw up to dimension "T".
- Screw lid in cover.

15 Shut-down

- Shut-down the pump/system and secure it against restarting!
- Make sure that all pipes with diaphragm relief valves are depressurized!
- Drain the diaphragm relief valve and the connected pipes using drain valves!
- Remove residues of the pumped medium out of the diaphragm relief valve by rinsing it with a compatible detergent!
- The diaphragm relief valve damper can then be removed out of the pipe.

16 Disposal

Shut-down system. Please see "Shut-down".

16.1 Dismantling and transport

- Remove all fluid residues, clean thoroughly, neutralize and decontaminate.
- Package unit and ship.

16.2 Complete disposal

- Remove all fluid residues from unit.
- Drain off lubricants and dispose of according to regulations!
- Dismount materials and send them to a suitable waste disposal company!

CAUTION !



The consignee is responsible for damage caused by leaking lubricants and fluids!

17 Clearance Certificate

NOTE!

Inspection / repair of machines and machine parts is only carried out after the opposite clearance certificate was filled in correctly and completely by authorized and qualified personnel.

NOTE!

Acceptance will be refused if parts are returned to the manufacturer without a proper clearance certificate.

All industrial companies are obligated by the legal provisions for occupational health, e.g. the workplaces ordinances, the Ordinance on Hazardous Substances, the regulations for prevention of accidents and the environmental protection regulations such as the Waste Management Act and the German Household Water Act to protect their employees or man and the environment from detrimental effects when handling hazardous substances.

Should special safety precautions be necessary despite careful draining and cleaning of the product the necessary information are to be provided.

Machines which are operated with radioactive media shall only be inspected and/or repaired in the safety area of the owner by a **sera** specialized fitter.

The clearance certificate is part of the inspection-/repair order. **sera** reserves the right to refuse acceptance of the order for other reasons.

NOTE!

Please make a copy and leave the original with the operating instructions!

(can also be downloaded from: www.sera-web.com)

Operating Instructions

Clearance Certificate

Product

Type Serial-No.

the product was carefully emptied before shipping / delivery, and cleaned inside and outside. YES

Conveying medium











Designation Concentration %

Properties

Please tick!

 Harmless

If either of the listed properties, then enclose the appropriate safety and handling instructions.

<input type="checkbox"/>  Toxic	<input type="checkbox"/>  Corrosive	<input type="checkbox"/>  Flammable	<input type="checkbox"/>  Oxidising	<input type="checkbox"/>  Unhealthy
<input type="checkbox"/>  Explosive	<input type="checkbox"/>  Dangerous for the environment	<input type="checkbox"/>  Irritant	<input type="checkbox"/>  Bio-hazardous	<input type="checkbox"/>  Radioactive

The product was used with health or water-polluting substances and came up with labeling requirements and pollution prone media in contact. YES

NO

Special security arrangements with respect to health or water-hazardous media are in the further handling not required

required

The following safety precautions regarding rinsing, residual liquids and waste disposal are required:

Process data

The product was used with the following operating conditions described conveying medium:

Temperature °C Pressure bar

Sender

Company: _____ Telephone: _____

Contact person: _____ FAX: _____

Address: _____ E-mail: _____

Zip code, City: _____ Your order No: _____

We confirm that we have the information in this safety certificate (Clearance Certificate) have been correctly and completely and that the returned parts were carefully cleaned.

The parts are sent free of residues of dangerous amount.

Place, Date

Department

Signature
(and company stamp)



Notes

